

ARCHIVE

This information was updated on December 28, 2022. SHIMANO makes no warranty with respect to this information, including without limitation any warranty on the accuracy of measures, specifications and compatibility of the current products. Regarding any modification and new product information after December 28, 2022, please refer to the SHIMANO Business Customer Web Site or directly contact the sales person of our company.

SHIMANO

2022-2023

Products compatibility Information

Compatibilities are subject to change without prior

Visit SHIMANO PRODUCT WEBSITE for the latest information.

Word definitions

BB	Bottom bracket	HP	Head parts
BC	Brake cable	HRB	Hub roller brake
BCC	Charger cord	I-SPEC	Integration mounting system of brake and shift lever
BCR	Battery charger		
BH	Disc brake hose	ID	CI-DECK
BL	Brake lever	JC	Junction
BM	Battery mount	LP	Light
BR	Brake caliper	MF	Multiple freewheel
BTC	Battery case	MU	Motor unit
BTR	Battery	O.L.D.	Over Locknut Dimension
CB	Coaster brake	OT	Outer casing
CD	Chain device	P.C.D.	Pitch Circle Diameter
CG	Chain guard	PCE	PC Linkage device
CJ	Cassette joint	PD	Pedal
CN	Chain	PM	POWER MODULATOR
CP	Spoke protector	QR	Quick release
CR	Chainring	RD	Rear derailleur
CS	Cassette sprocket	RT	Disc brake rotor
CT	Chain tensioner	RTAD	Disc brake rotor adapter
DH	Hub dynamo	SB	REVOSHIFT shifter integrated with brake lever
DU	Drive unit		
EC	Battery charger	SC	Cycle computer System information display
EW	Electric wire		
EWC	Cord cover	SF	Single freewheel
EWEX	Di2 adapter	SG	Internal geared hub
EWV	Wireless unit	SL	Shift lever
FC	Crankset	SPD	SHIMANO PEDALING DYNAMICS
	Crank arm	SPD-SL	SHIMANO PEDALING DYNAMICS-SL
FD	Front derailleur	ST	DUAL CONTROL LEVER : Shift lever integrated with brake lever
FH	FREEHUB		
GM	Grommet	SW	Switch unit
HB	Front hub	WH	Wheel

Compatibility

Drivetrain for MTB / URBAN components C-432

Rear drivetrain compatibility [MTB]

C-433 C-434 C-558 C-435 C-436 C-437 C-438 C-439
C-546

Front drivetrain compatibility [MTB, Trekking]

C-440 C-559 C-441 C-442 C-445 C-446

Front derailleur and crankset

C-447

Front derailleur and chain line (TOURNEY)

C-448

Crankset, bottom bracket and chain line [MTB]

C-449 C-450

Drivetrain for ROAD, Gravel, URBAN components C-453

Rear drivetrain compatibility

C-454

Front drivetrain compatibility

C-455

Brake system for ROAD, Gravel, URBAN components C-737

Brake systems compatibility [ROAD]

C-456

Hydraulic systems compatibility [ROAD, Gravel]

C-499

Hydraulic systems compatibility [URBAN]

C-500

I-SPEC C-156

Compatibility of I-SPEC shifter and brake lever

C-157

Disc brake C-460

Disc brake caliper and disc brake rotor compatibility C-461

Compatibility of lock ring with hubs C-612

Compatibility between brake systems (MT400 series) C-606

Combination chart (mechanical disc brake) C-462 C-463 C-464

Compatibility between hydraulic disc brake hose C-186 C-732 C-733

Compatibility between banjo screw C-625

Brake pad line-up C-192 C-652 C-653

Disc brake mount adapter C-193 C-194 C-195

Cable System C-605

Polymer-coated brake cable (BC-9000 / BC-R680) compatible chart C-306

V-BRAKE and Hub roller brake C-465

Compatibility between brake systems C-466

Brake lever with switch compatibility C-467 C-468 C-469

Cassette Sprocket C-544

FREEHUB and cassette sprocket spline compatibility C-731

Compatibility between rear derailleur and cassette sprocket gear teeth [ROAD, Gravel, URBAN (METREA)] C-254 C-648 C-255 C-256 C-257 C-258 C-259

LINKGLIDE cassette sprocket and FREEHUB compatibility C-649

URBAN (ALFINE, NEXUS) components C-470

Available combinations of the dropout, cassette sprocket/single gear and crankset for designing the frame C-471

Mechanical internal geared hub / SM (CJ) COMPATIBILITY CHART C-647

Single gear and chain combination C-608

CARGO BIKE related components C-651

Compatibility for DIN 79010:2020-02 C-672

Spoke protector C-298

Spoke protector C-491

MTB / URBAN (SHIMANO CUES) C-299

ROAD, Gravel, URBAN (METREA) C-300

Spoke protector for Road C-302

E-BIKE compatibility chart C-431

E-BIKE system compatibility chart C-525

Drivetrain compatibility C-488 C-706 C-655 C-656 C-657 C-658 C-659

Switch unit / cycle computer and brake lever compatibility C-421

Battery and battery mount compatibility C-511

System on/off function compatibility C-629

Speed sensor and drive unit compatibility C-549

Battery and battery charger compatibility C-562

ABS compatibility C-715

Electronic Product Information C-472

E-TUBE compatibility chart

C-473

Compatibility chart of CAN adapter for Di2

C-429

CI-DECK C-547

Compatibility between Bracket and ID/SC

C-548

ARCHIVE

Rear drivetrain compatibility [MTB]

C-433

9,10,11-speed rear drivetrain compatibility C-434

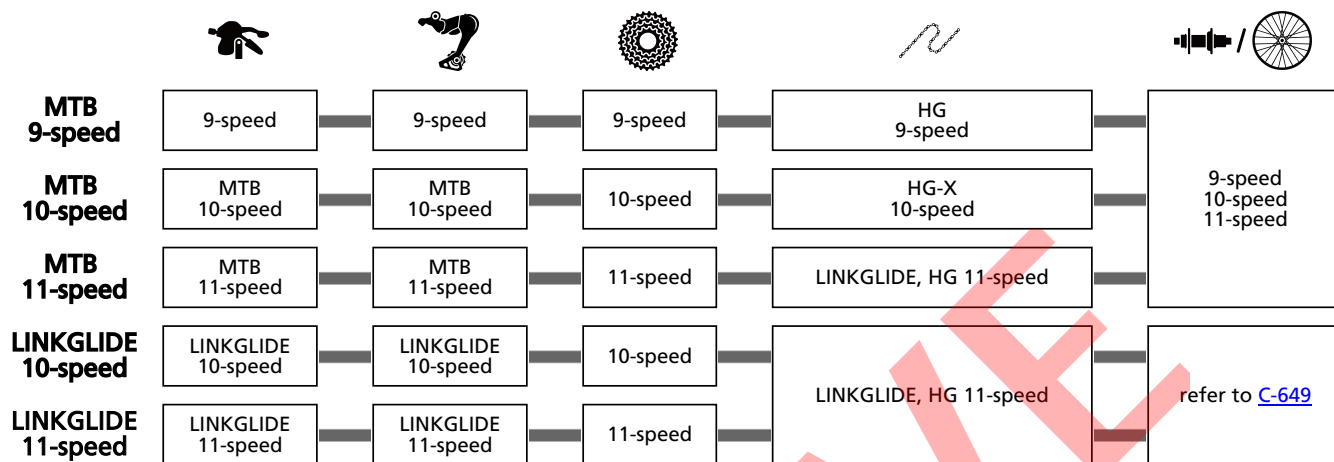

12-speed rear drivetrain (MICRO SPLINE) [MTB] C-558

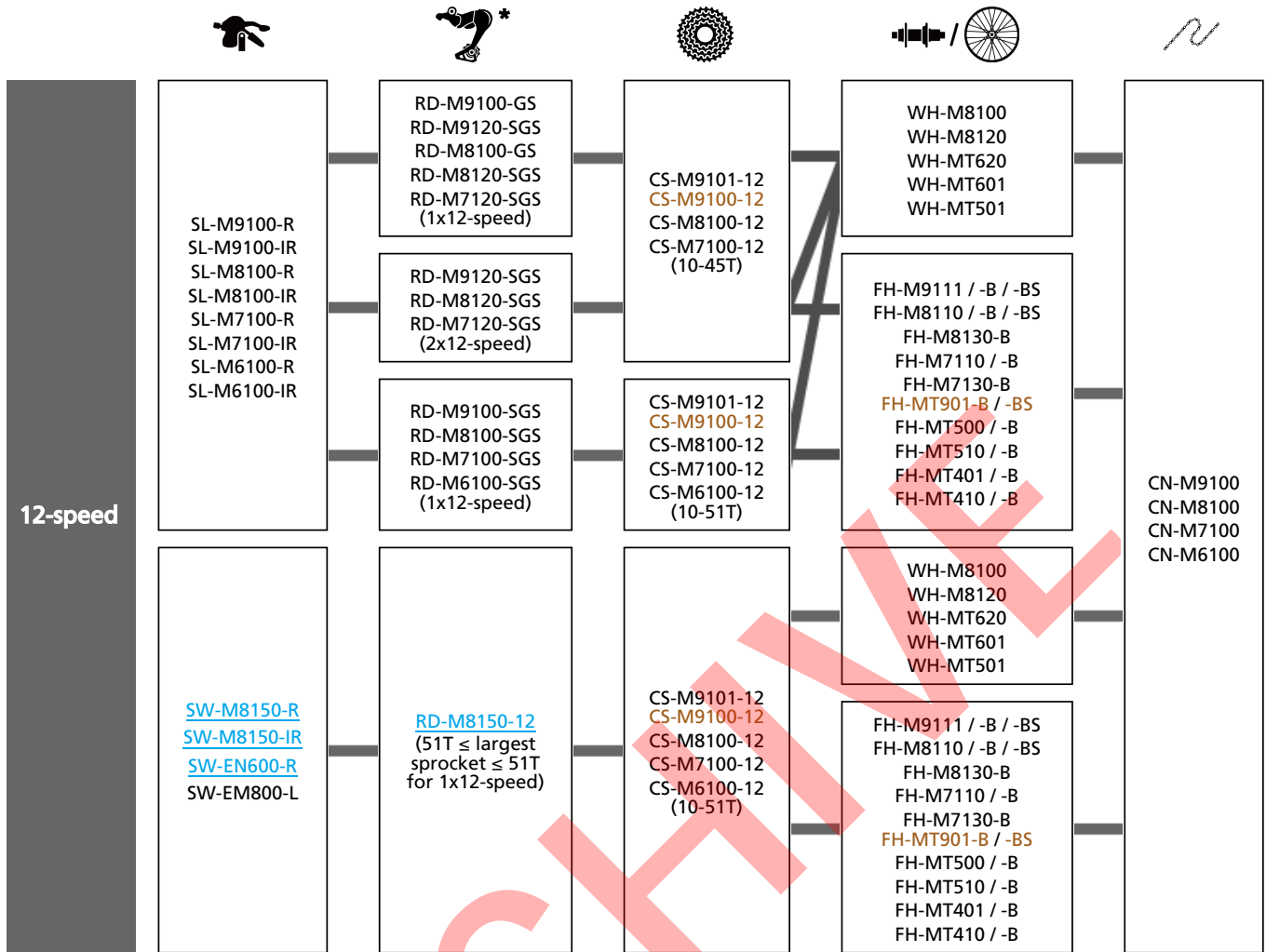

* Method to adjust the end adjustment screw is different from conventional rear derailleurs. For details, refer to dealer's manual.

NOTE
RD-M8150 is only for E-BIKE

11-speed rear drivetrain [MTB, URBAN (SHIMANO CUES)] C-435

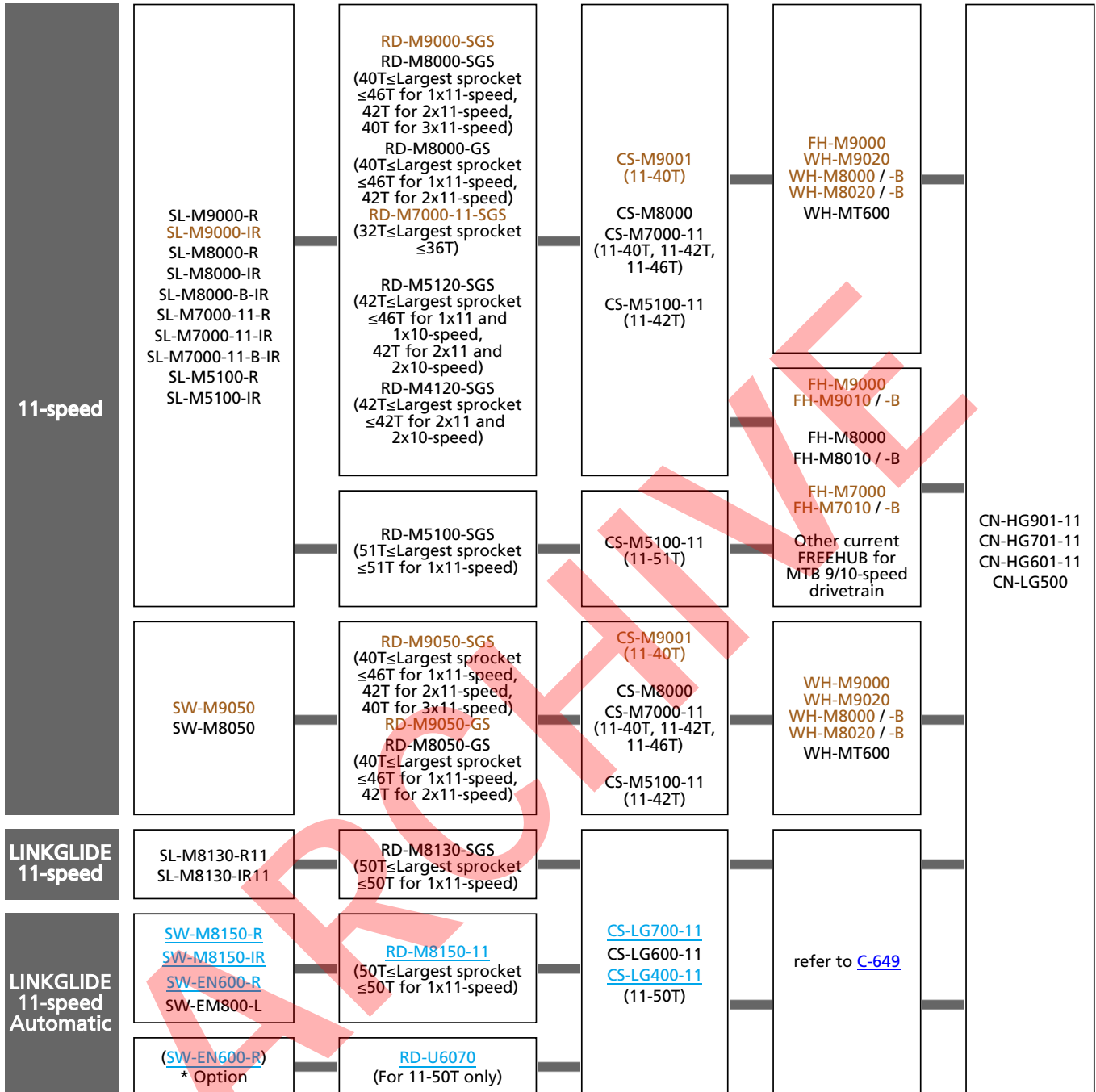
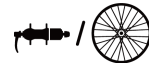

NOTE

- Automatic shift is only for E-BIKE
- [RD-M8150](#) is only for E-BIKE

10-speed rear drivetrain [MTB, URBAN (SHIMANO CUES)] C-436

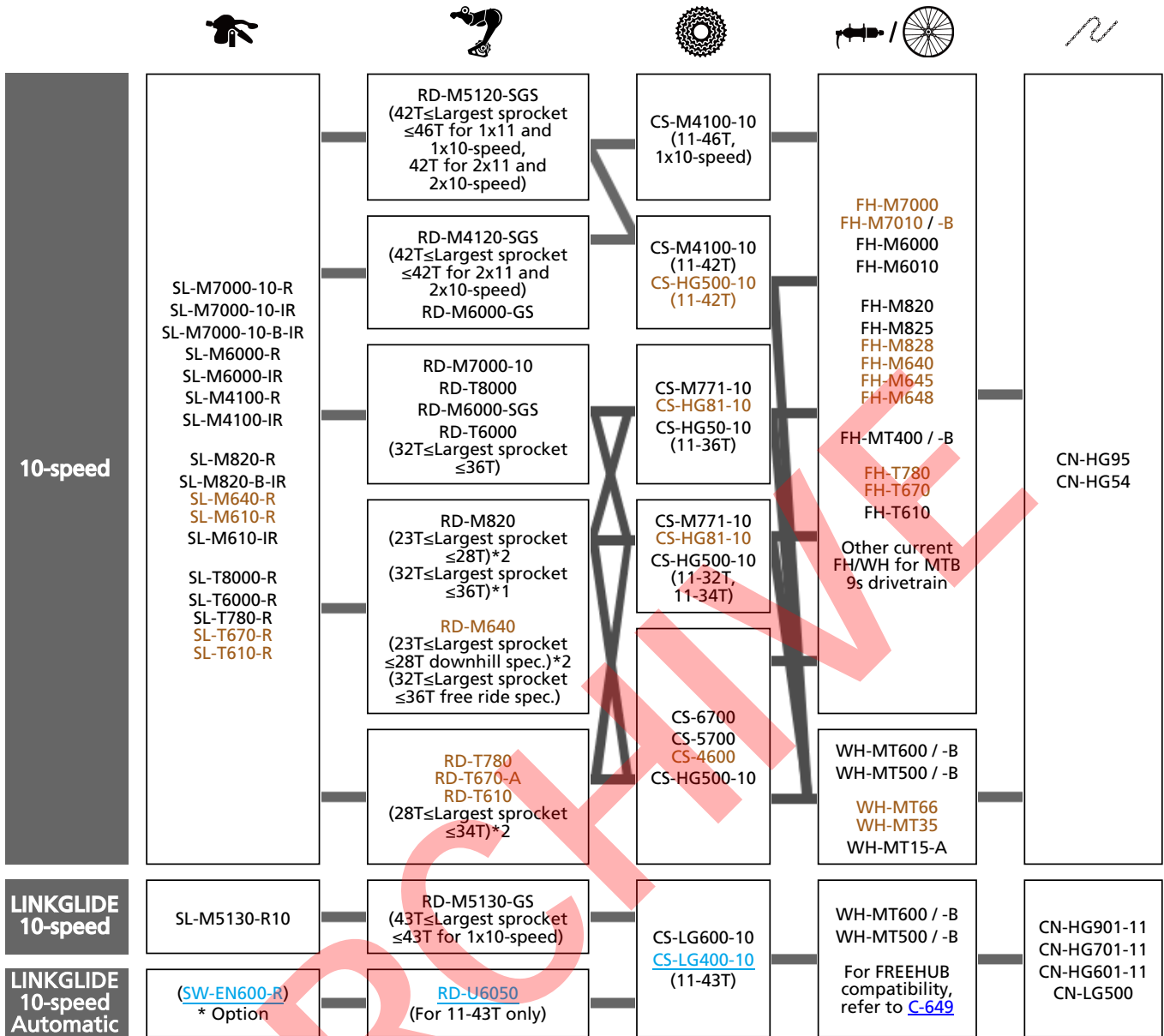

*1 Mode converter

*2 Compatible with road Cassette sprocket

NOTE

Automatic shift is only for E-BIKE

9-speed rear drivetrain [MTB] C-437

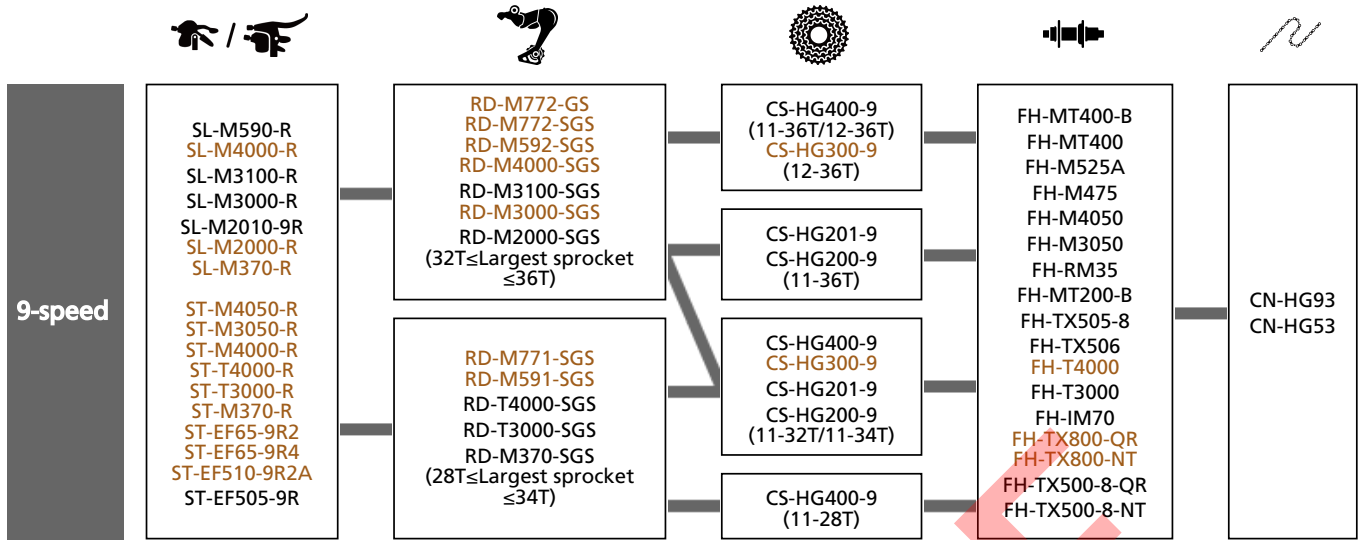

8-speed HG [MTB] C-438

The rear derailleur for 8-speed can also be used for 7-speed drivetrain.

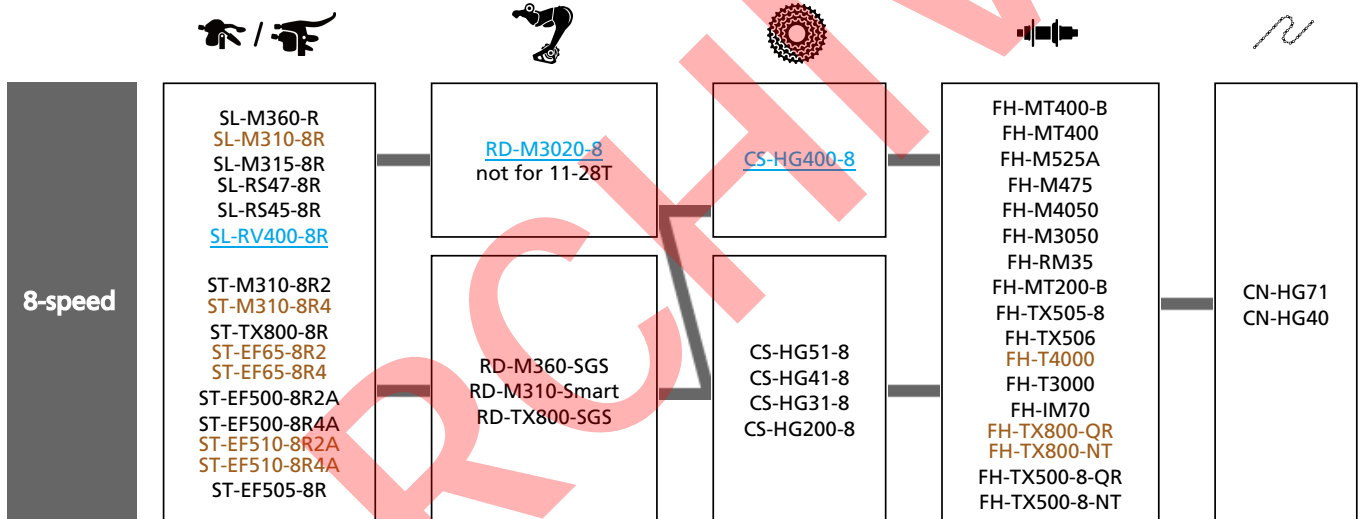

7-speed HG [MTB] C-439

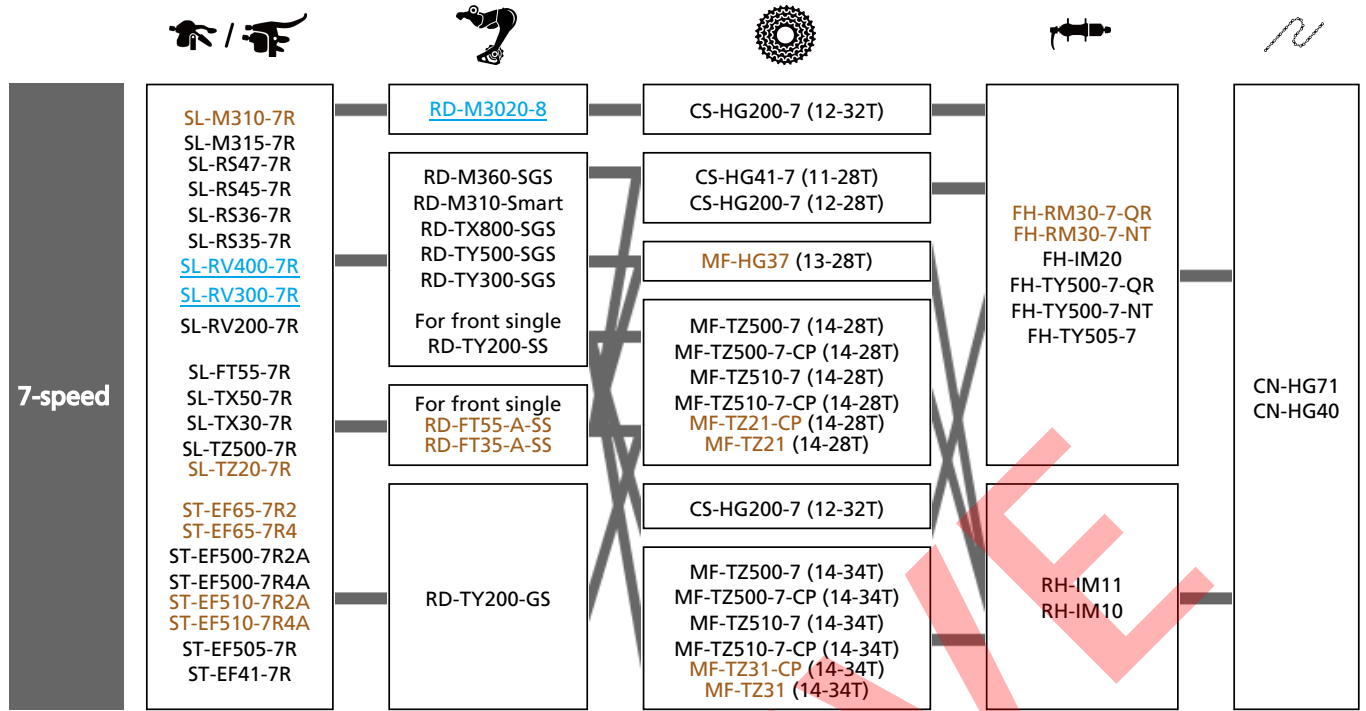

6-speed HG and 6-speed [MTB] C-546

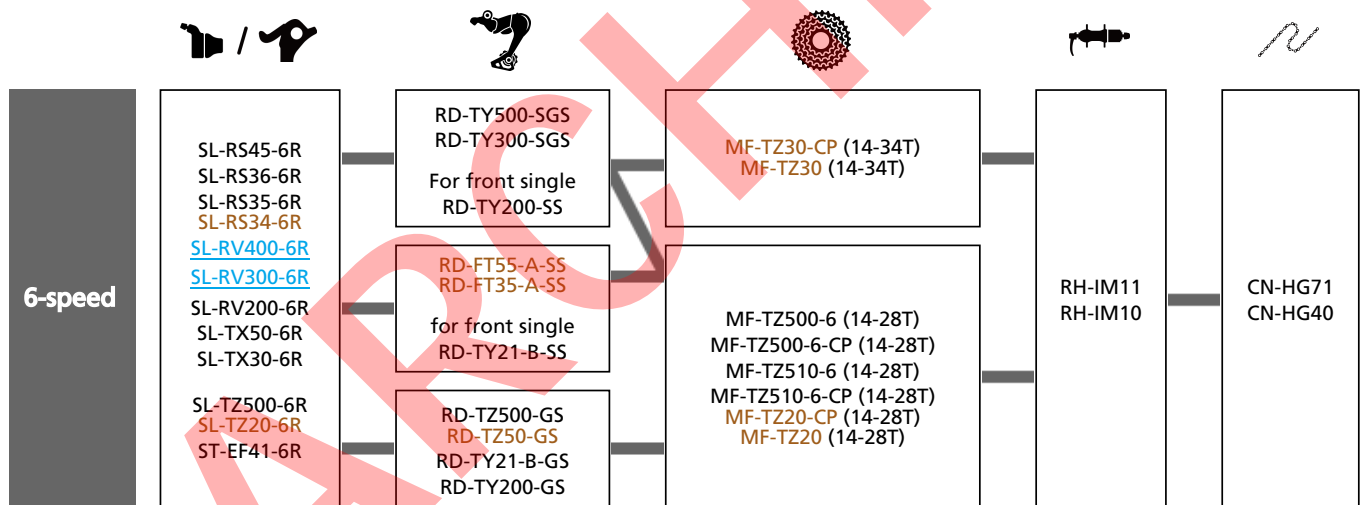

12-speed front drivetrain [MTB] C-559

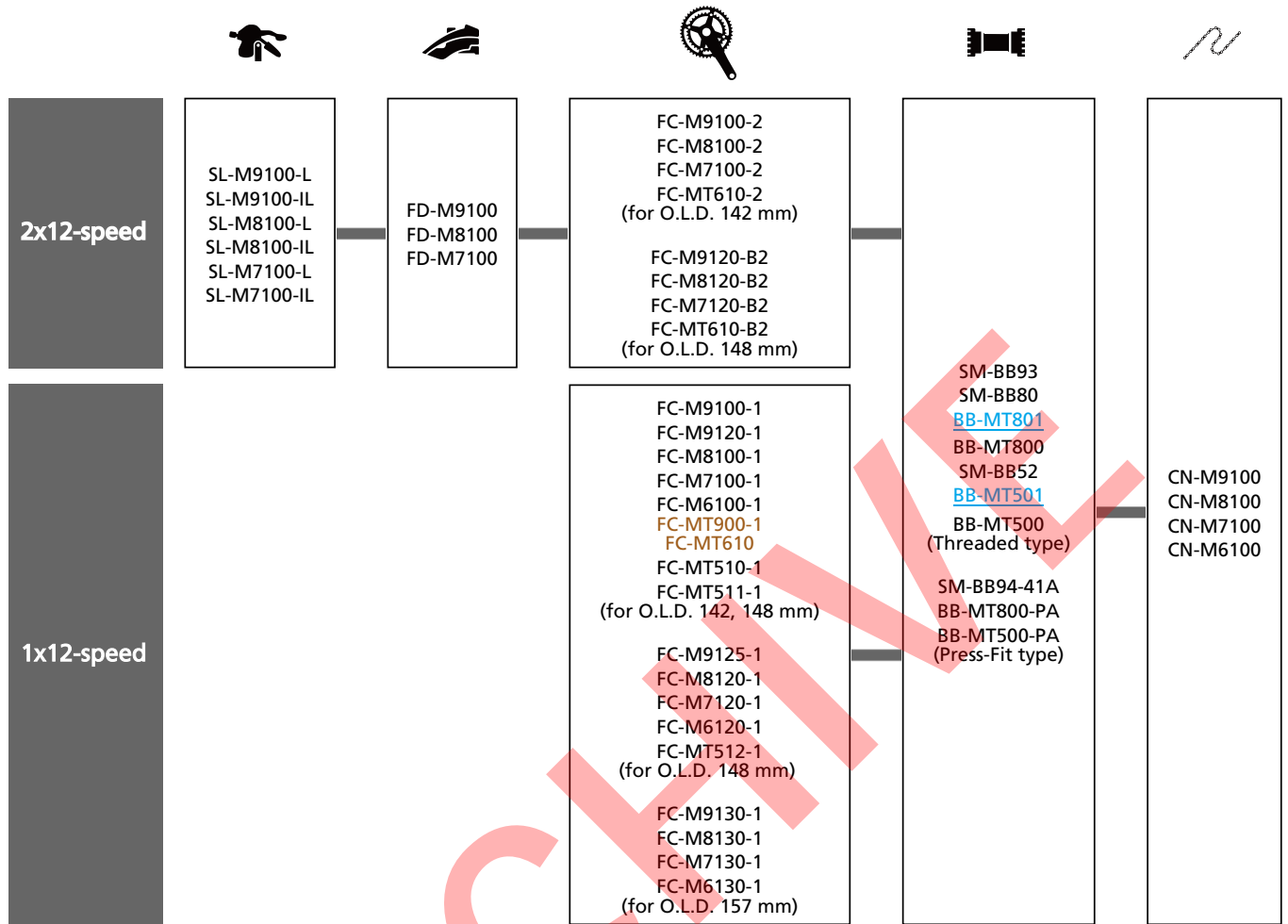

11-speed front drivetrain [MTB] C-441

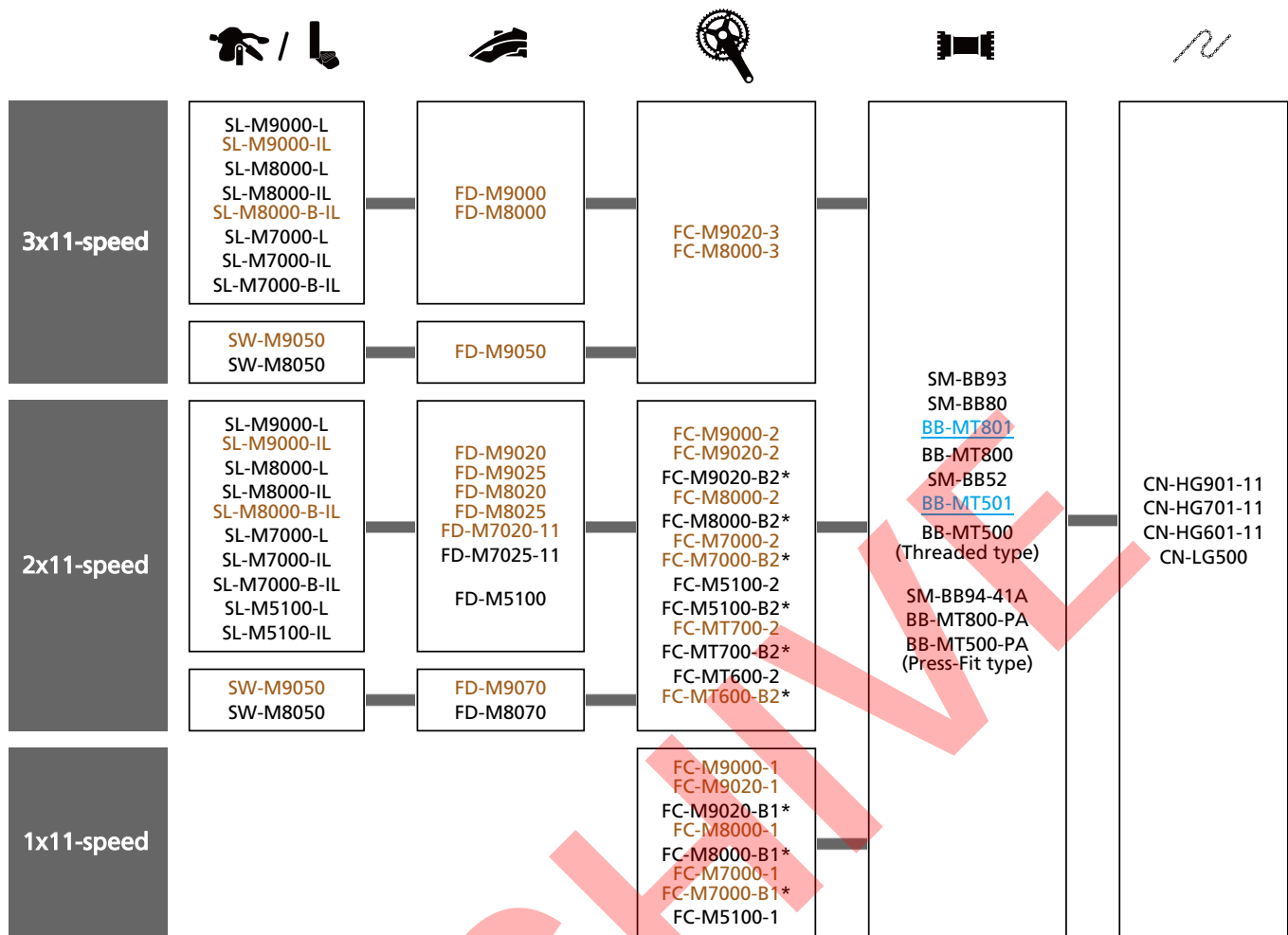

NOTE

* Requires the dimension of frame which cassette sprocket position is 3 mm outboard.

10-speed front drivetrain [MTB, Trekking] C-442

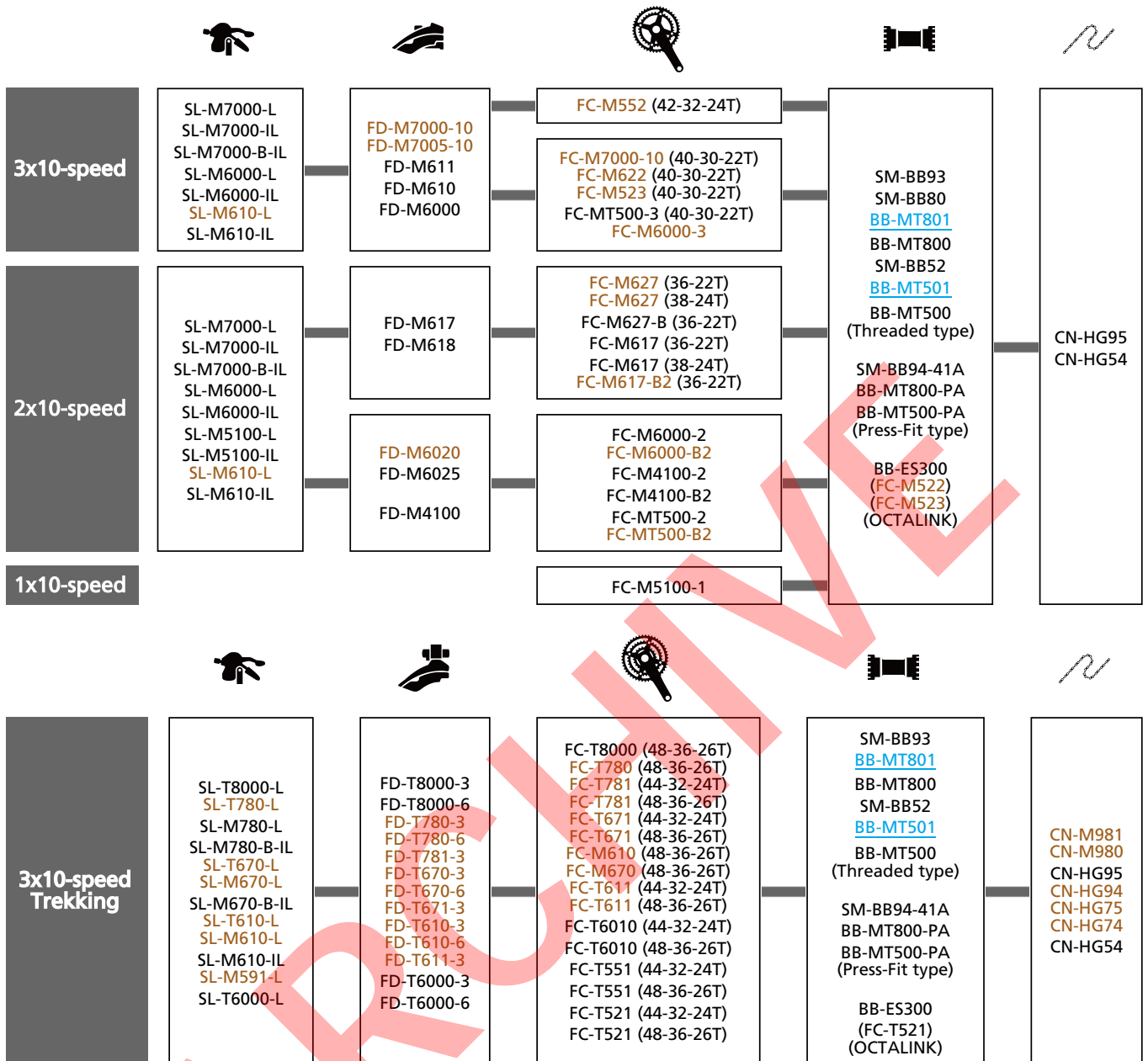

9-speed FC-FD compatibility [MTB] C-445

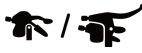

3x9-speed

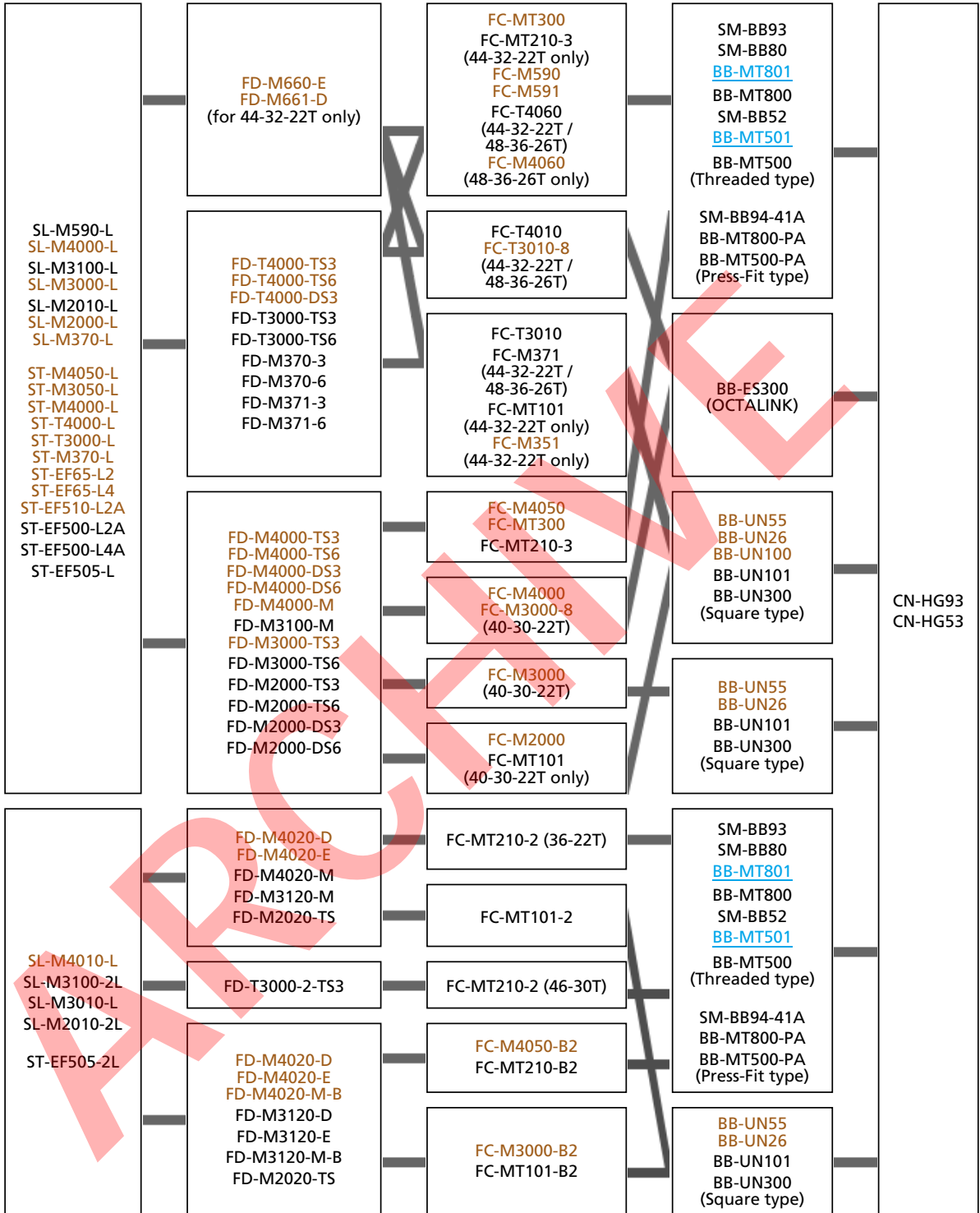

8,7,6-speed FC-FD compatibility [MTB] C-446

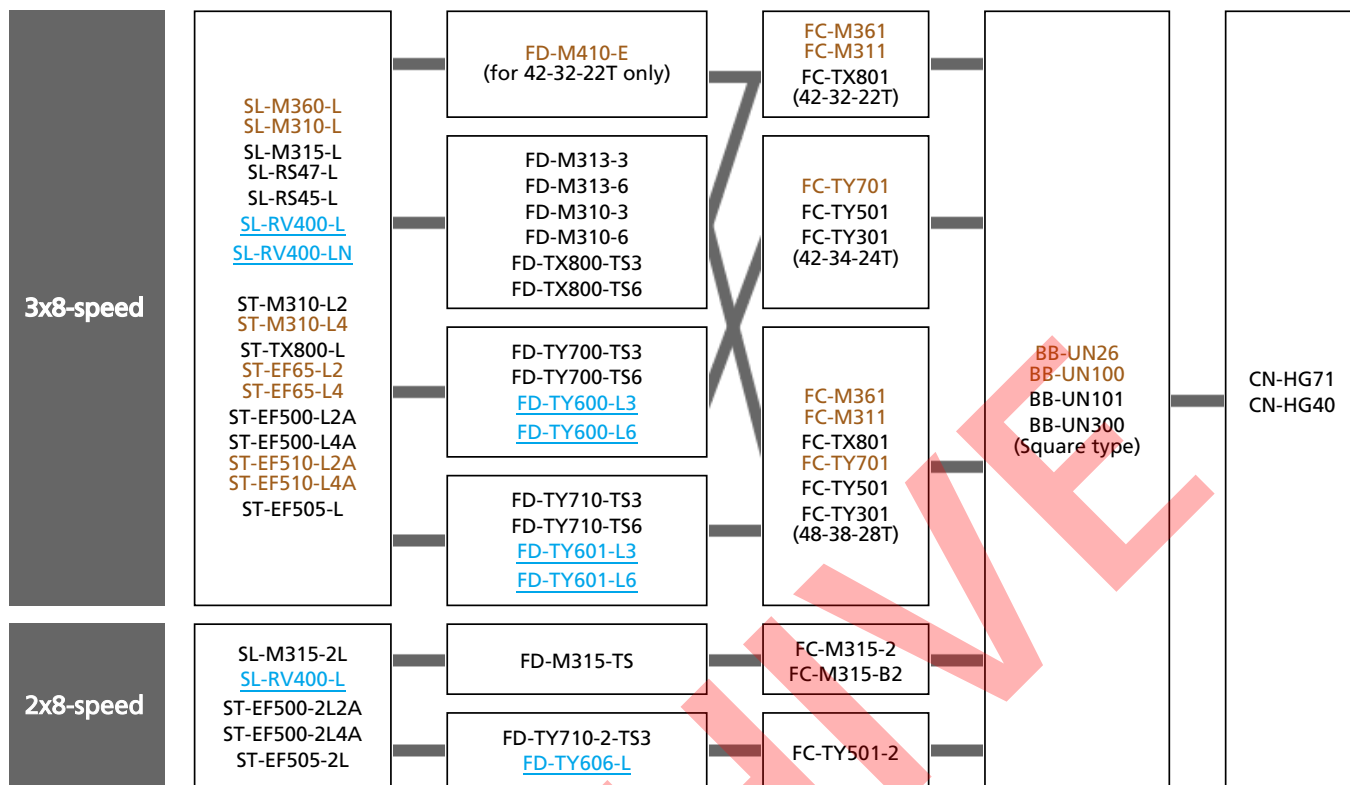

ARCHIVED

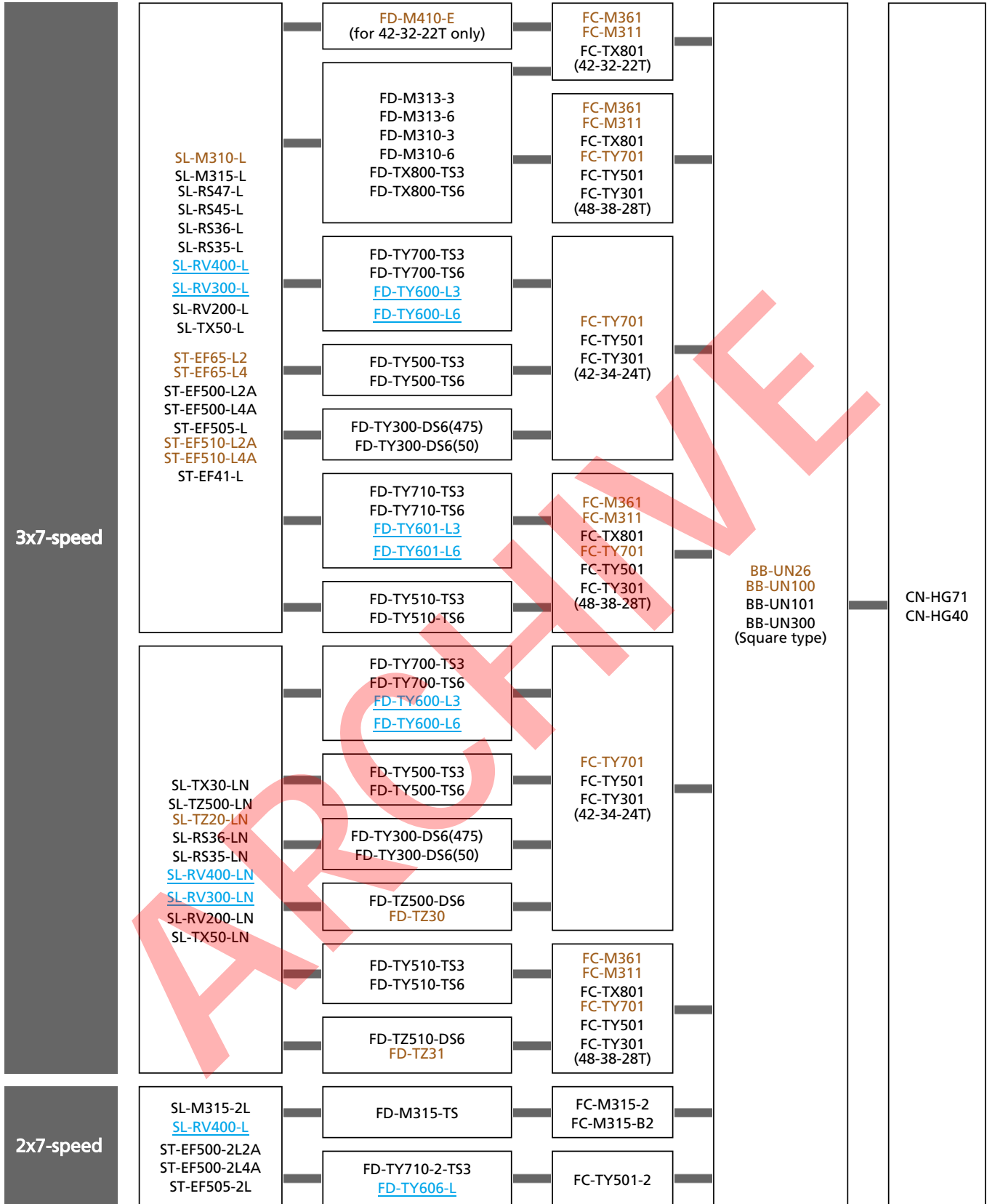
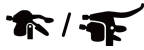

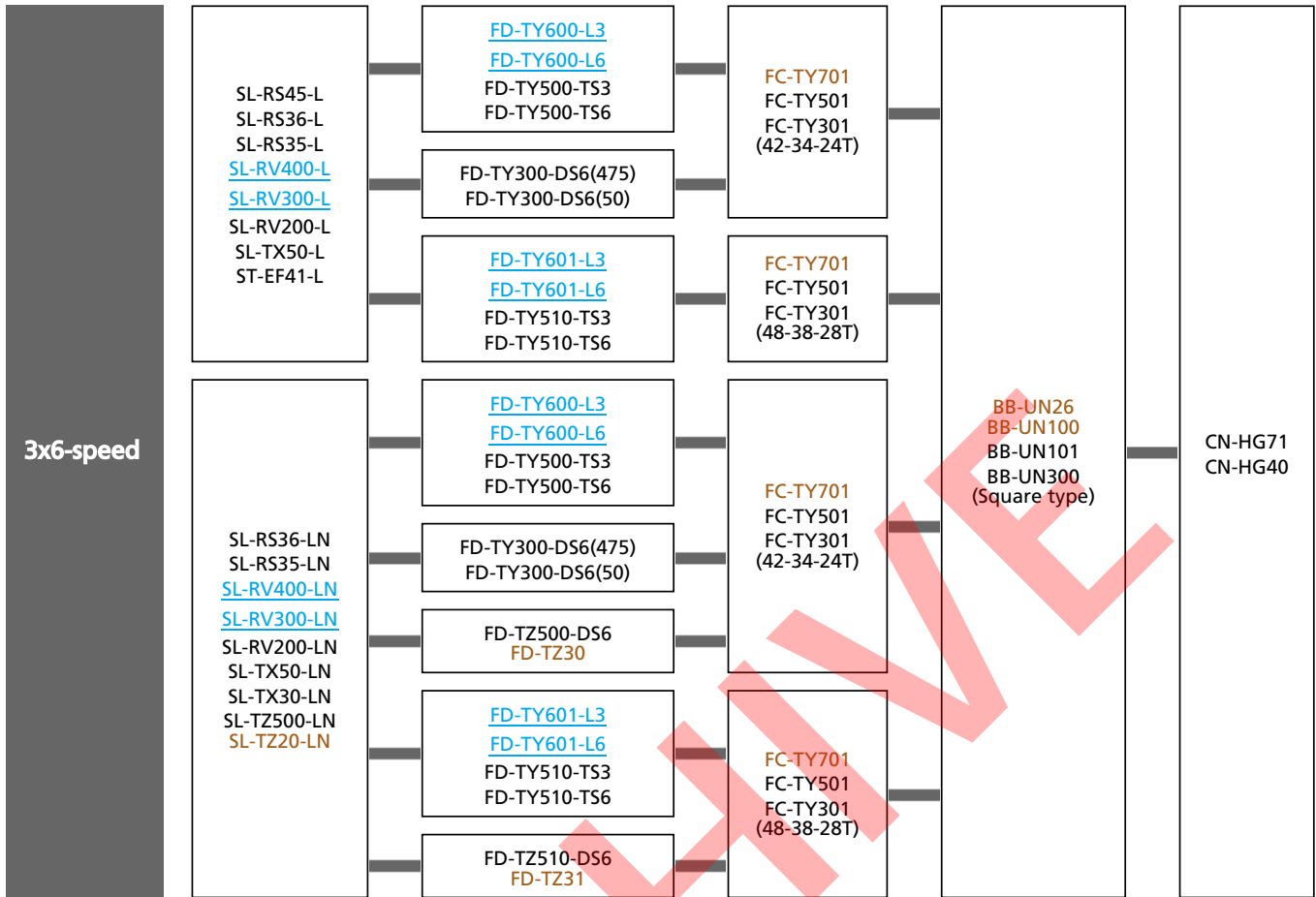
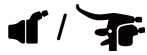

Front derailleur and crankset

C-447

The allowable combinations of front derailleurs depend on the difference in the number of teeth of the gears and the shape of the front derailleur plate.

If the conditions given below are not satisfied, then the desired shiftability may not be obtained.

$$FC \text{ (largest chainring)} - \text{(smallest chainring)} \leq FD \text{ (high and low capacity)}$$

$$FC \text{ (largest chainring)} - \text{(middle chainring)} = FD \text{ (allowance of difference in teeth number between top and middle)}$$

Each front derailleurs and the number of teeth of corresponding cranksets are given in the compatibility chart.

Front derailleur and chain line (TOURNEY)

C-448

The SHIMANO line-up for front derailleurs and the chain lines they support are given in the chart below.

		28.6 mm (S)	31.8 mm (M)	34.9 mm (L)
Chain line (mm)	FD-TY300-DS6(475)		47.5	-
	FD-TY300-DS6(50)		-	50.0
	FD-TZ510-DS6 FD-TZ500-DS6 FD-TZ31 FD-TZ30		47.5	-

Crankset, bottom bracket and chain line [MTB]

C-449

In order to use SIS (SHIMANO INDEX SYSTEM) to its full extent, the required correct chain line, along with the crankset and bottom bracket required to obtain that, are given in the chart below.

Separate type FC-BB compatibility [MTB] C-450

Speed	Series	Crankset				Bottom bracket	Chain line and axle mark						
		Model No.	Type of crank				Model No.	47.5 mm	50.0 mm	52.5 mm	47.5+t mm	48.8 mm	51.8 mm
			OCTALINK	Square	Chain case								
10	SHIMANO	FC-M523	✓	-	-	BB-ES300	-	118	-	-	-	-	
		FC-M522	✓	-	-	BB-ES300	-	113	-	-	-	-	
9	SHIMANO	FC-M521	✓	-	✓*1	BB-ES300-AK	-	*2	-	-	-	-	
		FC-M4000	✓	-	-	BB-ES300	-	118	-	-	-	-	
	ALIVIO	FC-T4010	✓	-	✓*1	BB-ES300(-K)	-	126(-K)	-	-	-	-	
		FC-M430-8	✓	-	-	BB-ES300(-E)	-	118(-E)	-	-	-	-	
		FC-M430	-	✓	-	BB-UN26(-E) BB-UN300(-E)	-	LL113(-E)	-	-	-	-	
	ACERA	FC-M3000-8	✓	-	-	BB-ES300	-	118	-	-	-	-	
		FC-M3000 FC-M3000-B2	-	✓	-	BB-UN26 BB-UN300	-	LL113	-	-	-	-	
		FC-T3010-8	✓	-	✓*1	BB-ES300(-K)	-	126(-K)	-	-	-	-	
		FC-T3010	-	✓	✓*1	BB-UN26(-K) BB-UN300(-K)	-	LL123(-K)	-	-	-	-	
	ALTUS	FC-M2000	-	✓	-	BB-UN26 BB-UN300 BB-UN100 BB-UN101	-	LL123(-K)	-	-	-	-	
	SHIMANO	FC-MT100 FC-MT101	-	✓	-	BB-UN26 BB-UN300 BB-UN100 BB-UN101	-	LL123	-	-	-	-	
		FC-M371	-	✓	✓*1	BB-UN26(-K) BB-UN300(-K)	-	LL123(-K)	-	-	-	-	
		FC-M351	-	✓	✓*1	BB-UN26(-K) BB-UN300(-K)	-	LL123(-K)	-	-	-	-	
	8, 7	ACERA ALTUS	FC-M361 FC-M311	-	✓	✓*1	BB-UN26(-K) BB-UN300(-K)	-	LL123(-K)	-	-	-	-
TOURNEY		FC-TX801	-	✓	✓*1	BB-UN26(-K) BB-UN300(-K) BB-UN100(-K) BB-UN101(-K)	-	LL123(-K)	-	-	-	-	
			FC-M315-2	-	✓	-	BB-UN26 BB-UN300 BB-UN100 BB-UN101	-	-	-	-	LL123	-
SHIMANO		FC-M315-B2	-	✓	-	BB-UN26 BB-UN300 BB-UN100 BB-UN101	-	-	-	-	-	LL123	
		FC-TY501-2	-	✓	-	BB-UN26 BB-UN300 BB-UN100 BB-UN101	-	-	-	-	LL123	-	
8, 7, 6		SHIMANO	FC-TY701 FC-TY501 FC-TY301	-	✓	✓	BB-UN26(-K) BB-UN300(-K) BB-UN100(-K) BB-UN101(-K)	D-NL (122.5)	BB-UN26(-K) BB-UN300(-K) D-EL(-K)	-	D-NL-K (122.5)	-	-

*1 Chain case stay thickness should be 1.5 mm to 2.1 mm.

*2 Please refer to [C-445](#) for detailed combination.

NOTE

- If using a chain case, select a BB-xxxx (-K) / -K bottom bracket.
- If using an E-type front derailleur, select a BB-xxxx (-E) bottom bracket.
- **FC-M521**: Use 121AK with 1.8 mm spacer if no chain case used.

Rear drivetrain compatibility

C-454

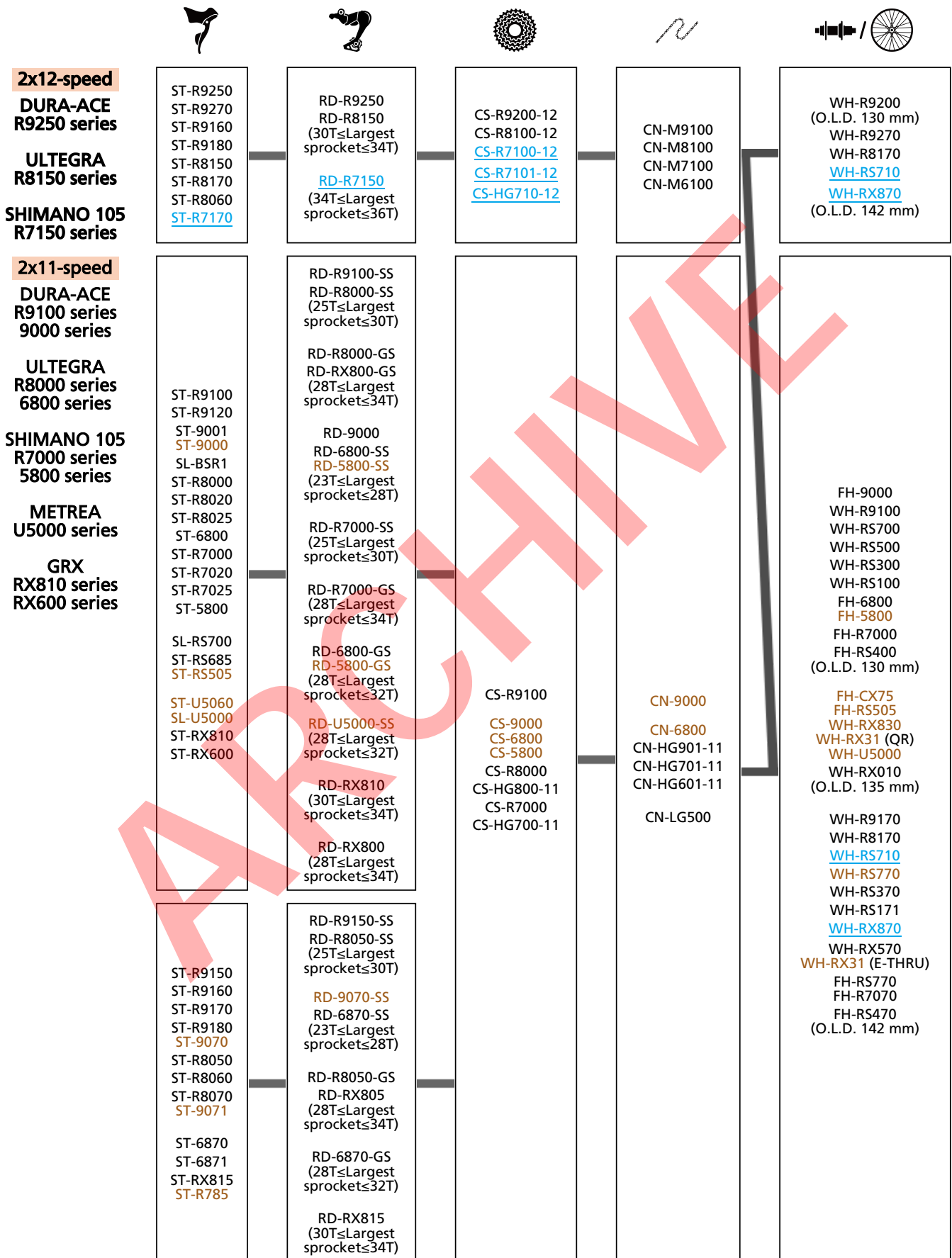



1x11-speed
METREA
U5000 series

ST-U5060
SL-U5000

RD-U5000-SS

CS-R9100
CS-9000
CS-6800
CS-5800
CS-R8000
CS-HG800-11
CS-R7000
CS-HG700-11

CN-9000
CN-6800
CN-HG901-11
CN-HG701-11
CN-HG601-11
CN-LG500

FH-9000
WH-R9100
WH-RS700
WH-RS500
WH-RS300
WH-RS100
FH-6800
FH-5800
FH-R7000
FH-RS400
(O.L.D. 130 mm)
FH-CX75
FH-RS505
WH-RX830
WH-RX31 (QR)
WH-U5000
WH-RX010
(O.L.D. 135 mm)
WH-R9170
WH-R8170
WH-RS710
WH-RS770
WH-RS370
WH-RS171
WH-RX870
WH-RX570
WH-RX31 (E-THRU)
FH-RS770
FH-R7070
FH-RS470
(O.L.D. 142 mm)

GRX
RX810 series
RX600 series

ST-RX810
ST-RX600

RD-RX812
(40T ≤ Largest sprocket ≤ 42T)

CS-M8000-11
CS-M7000-11
CS-M5100-11

ST-R9150
ST-R9160
ST-R9170
ST-R9180
ST-9070
ST-R8050
ST-R8060
ST-R8070
ST-9071
ST-6870
ST-6871
ST-RX815
ST-R785

RD-RX817
(40T ≤ Largest sprocket ≤ 42T)

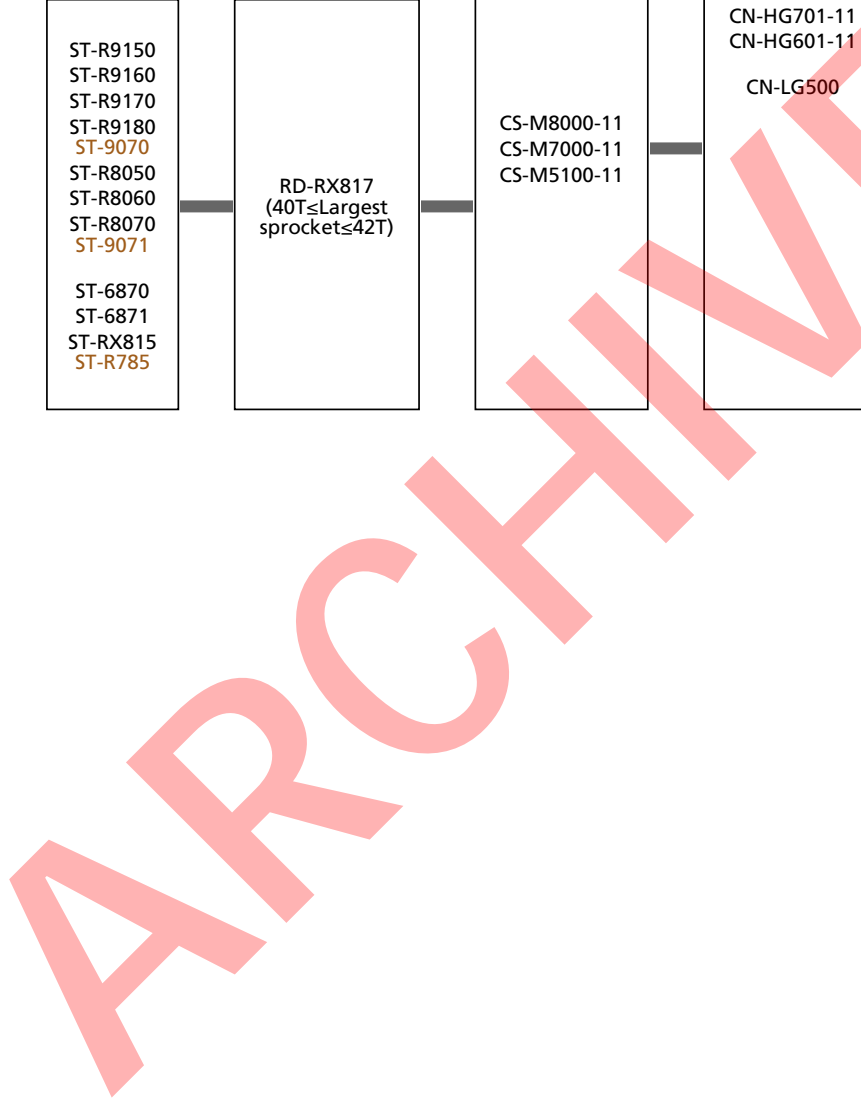



2x10-speed

**ULTEGRA
6700 series**

**SHIMANO 105
5700 series**

**TIAGRA
4700 series
4600 series**

**GRX
RX400 series**

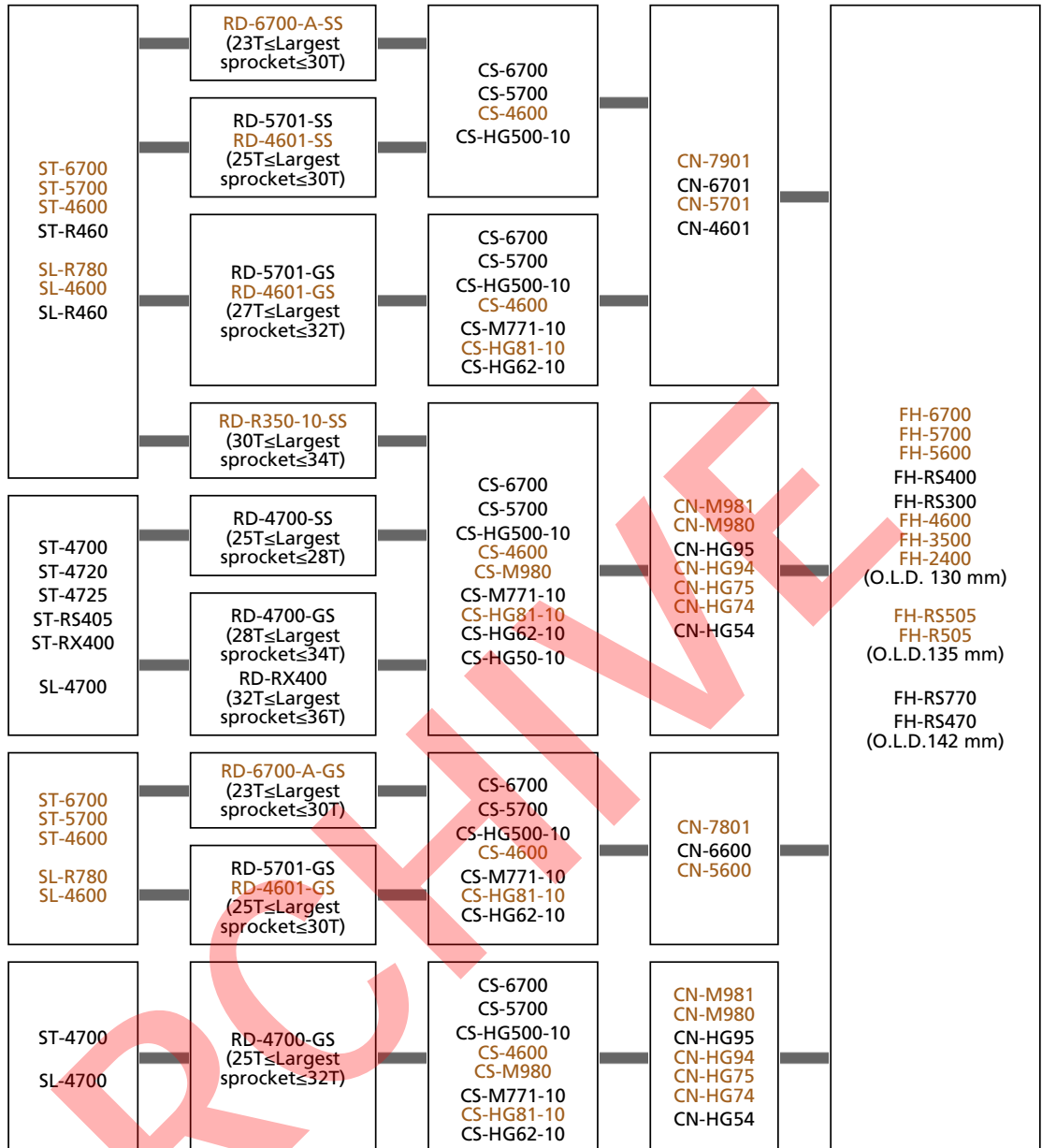

3x10-speed

**ULTEGRA
6700 series**

**SHIMANO 105
5700 series**

**TIAGRA
4700 series
4600 series**



2x9-speed
SORA
R3000 series
3500 series

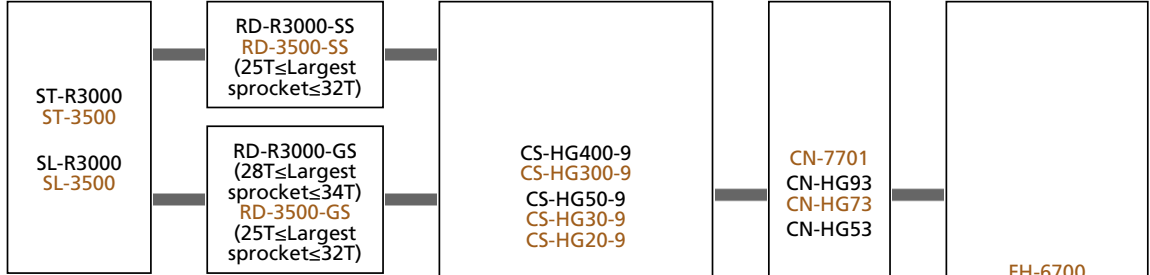

3x9-speed
SORA
3500 series



2x8-speed
CLARIS
R2000 series
2400 series

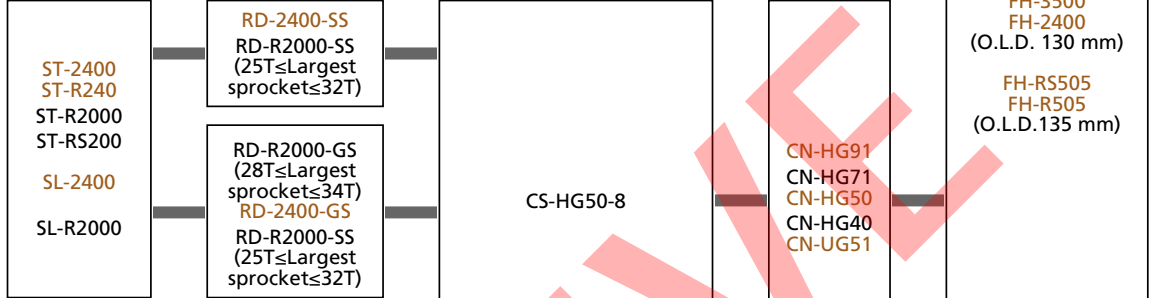

2/3x8-speed
2300 series



2/3x7-speed
TOURNEY
A070 series
A050 series

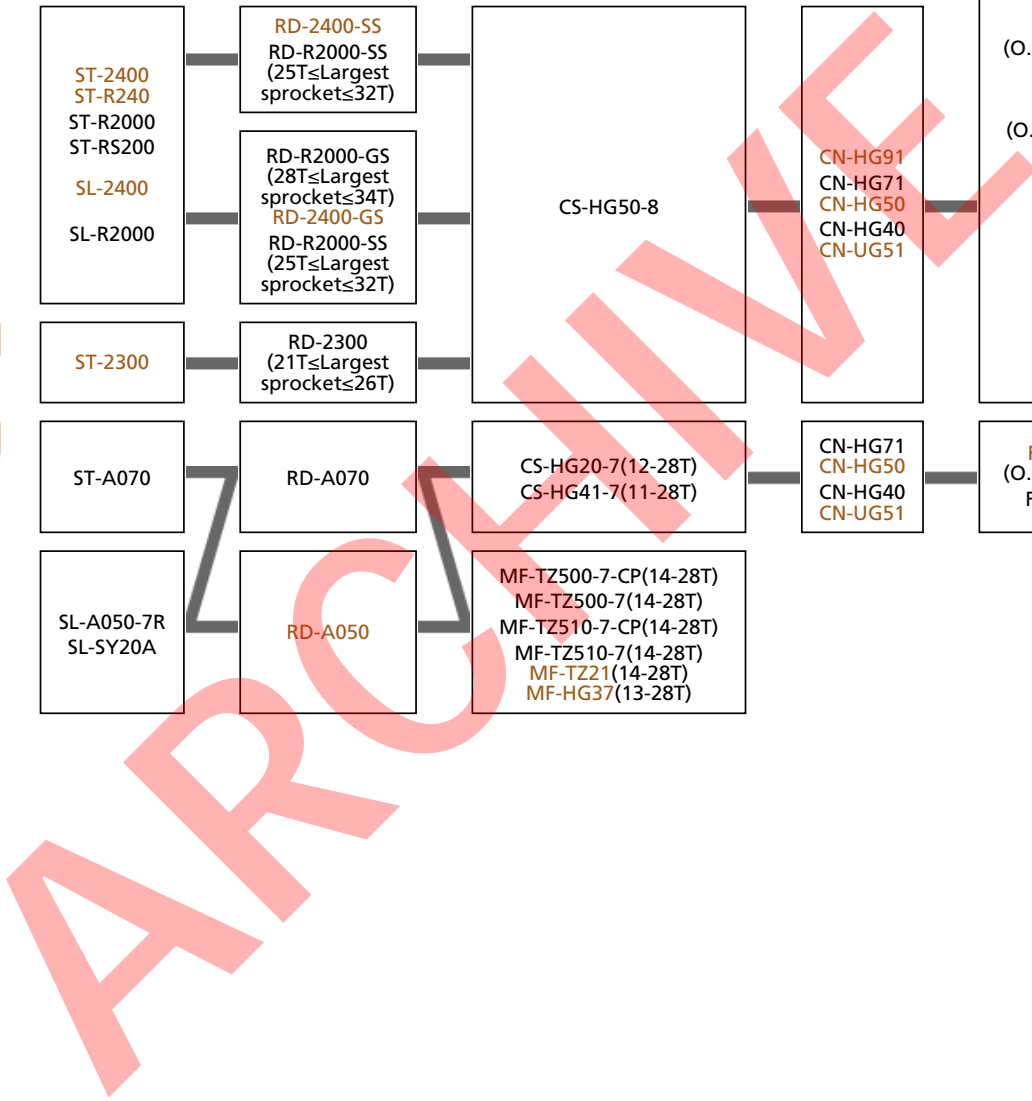

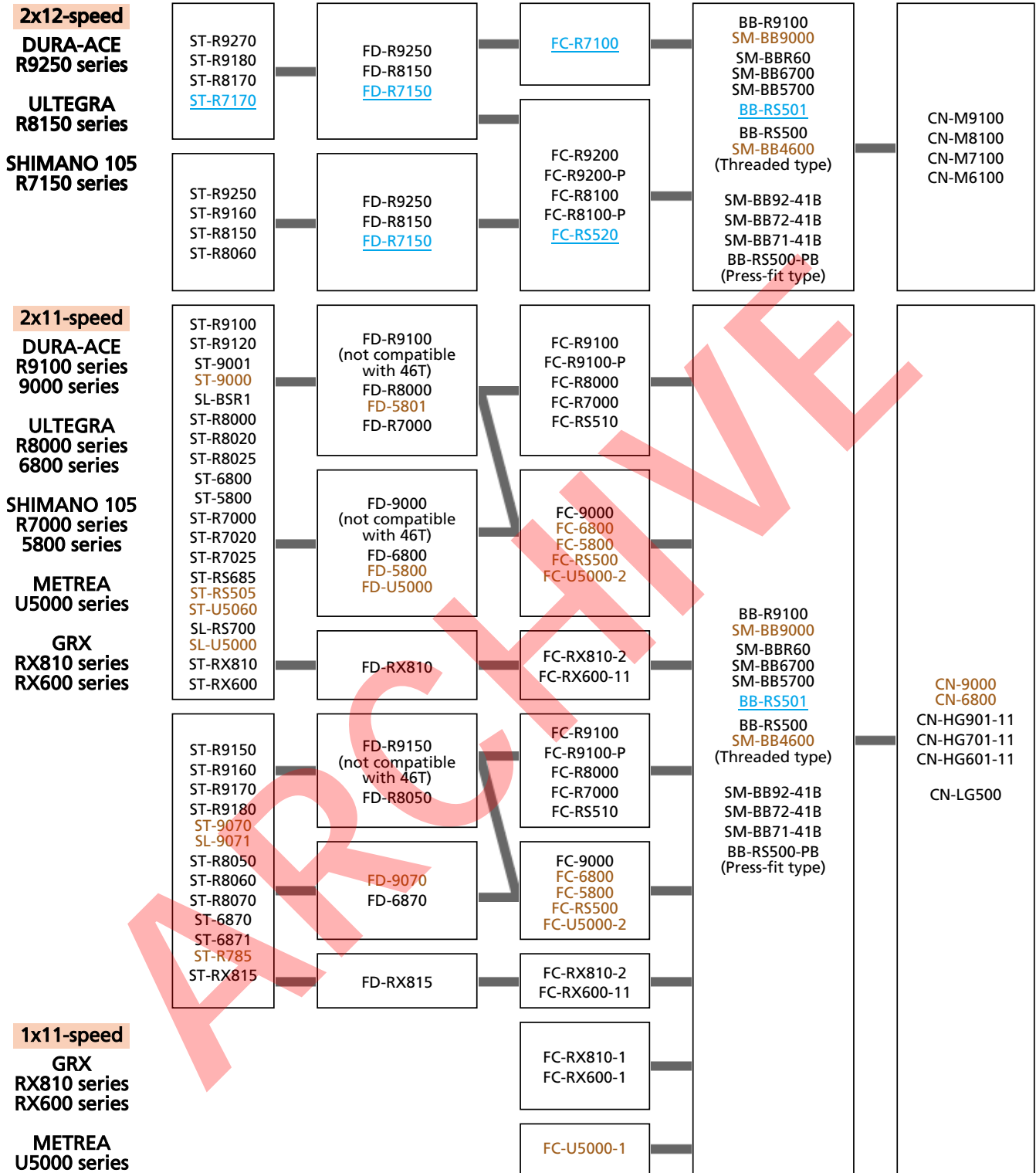



2x10-speed

**ULTEGRA
6700 series**

**SHIMANO 105
5700 series**

**TIAGRA
4700 series
4600 series**

**GRX
RX400 series**

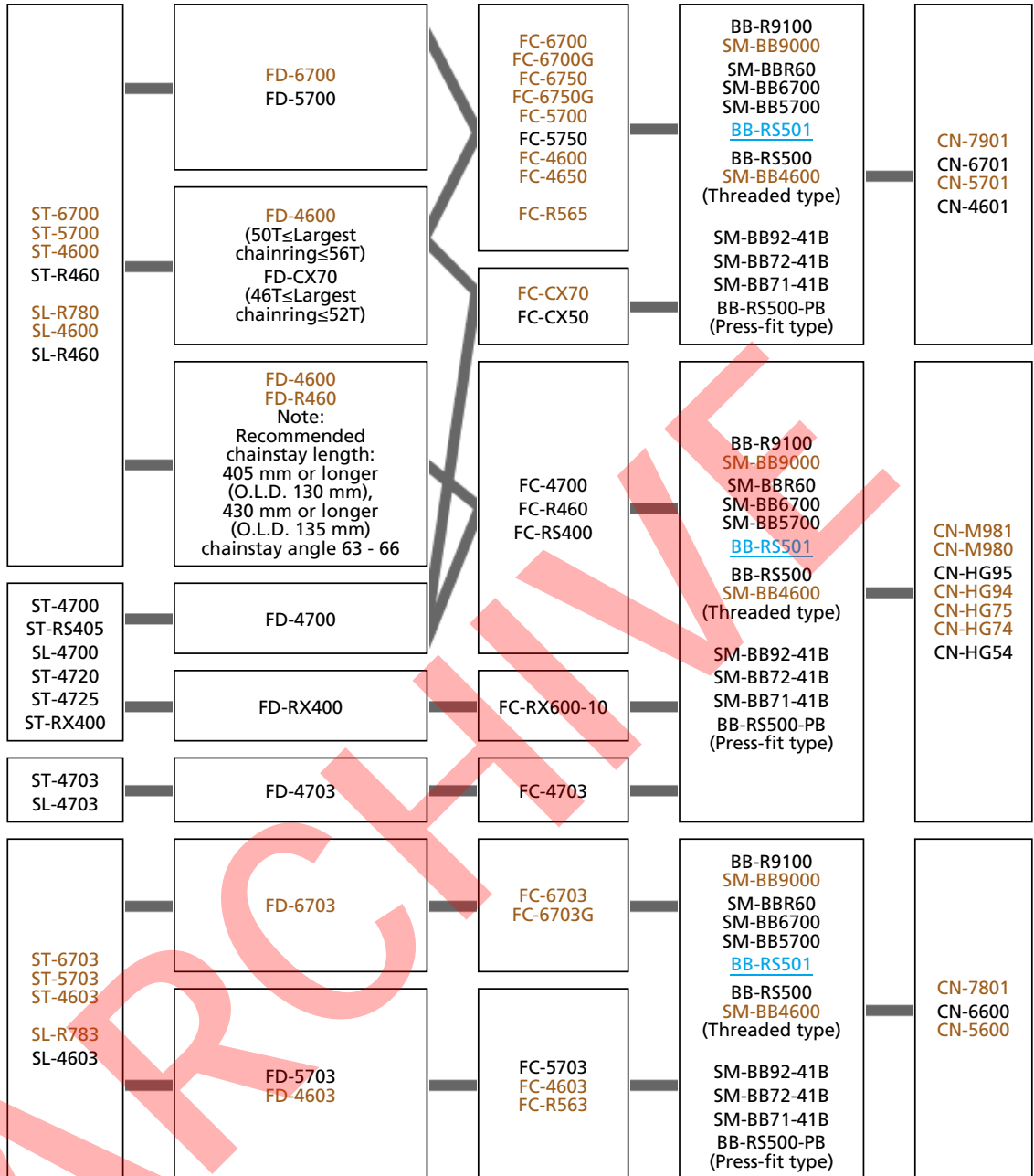

3x10-speed

**ULTEGRA
6703 series**

**SHIMANO 105
5703 series**

**TIAGRA
4703 series
4603 series**

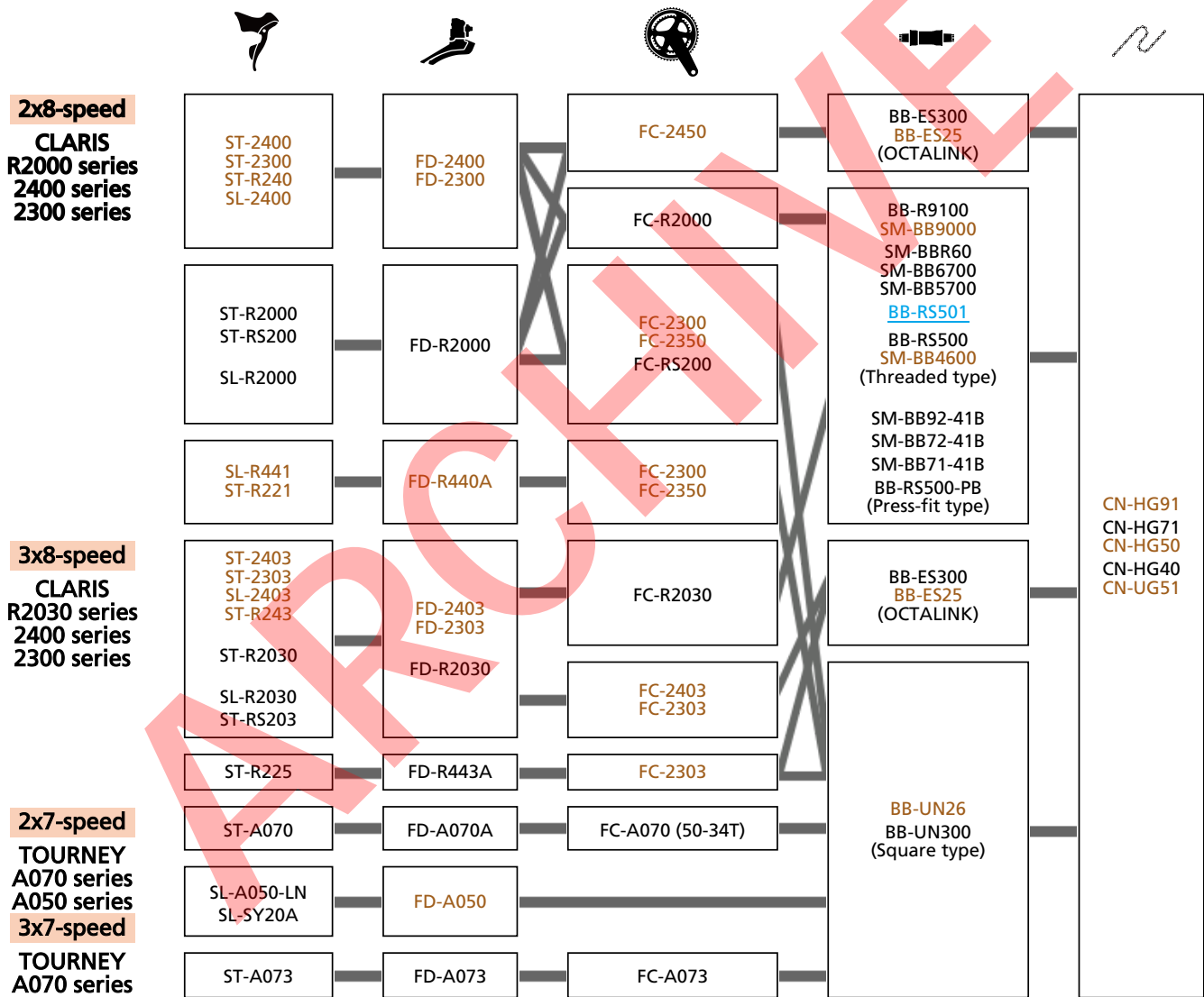
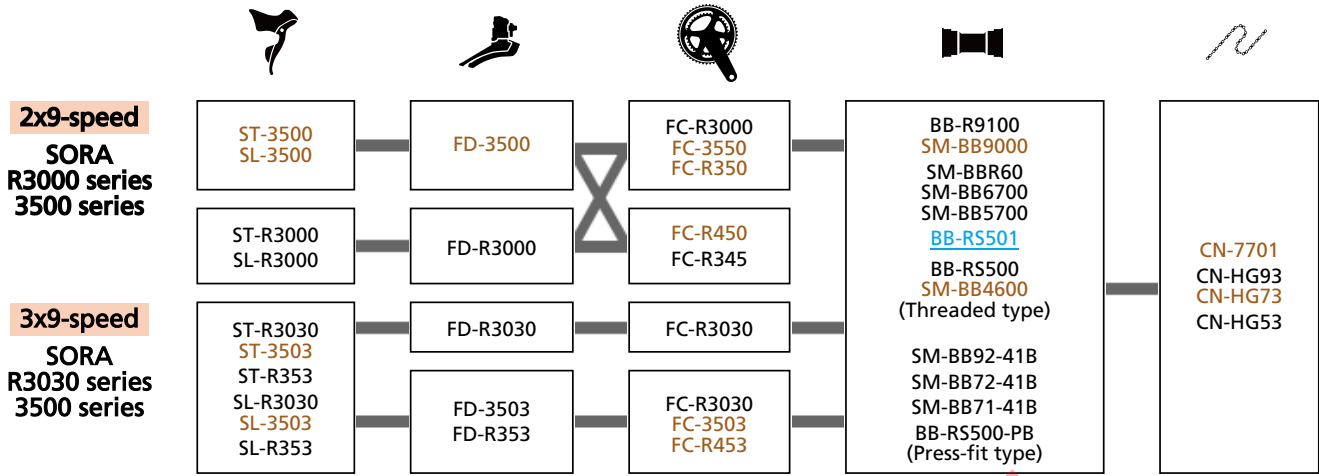

Brake systems compatibility [ROAD]

C-456

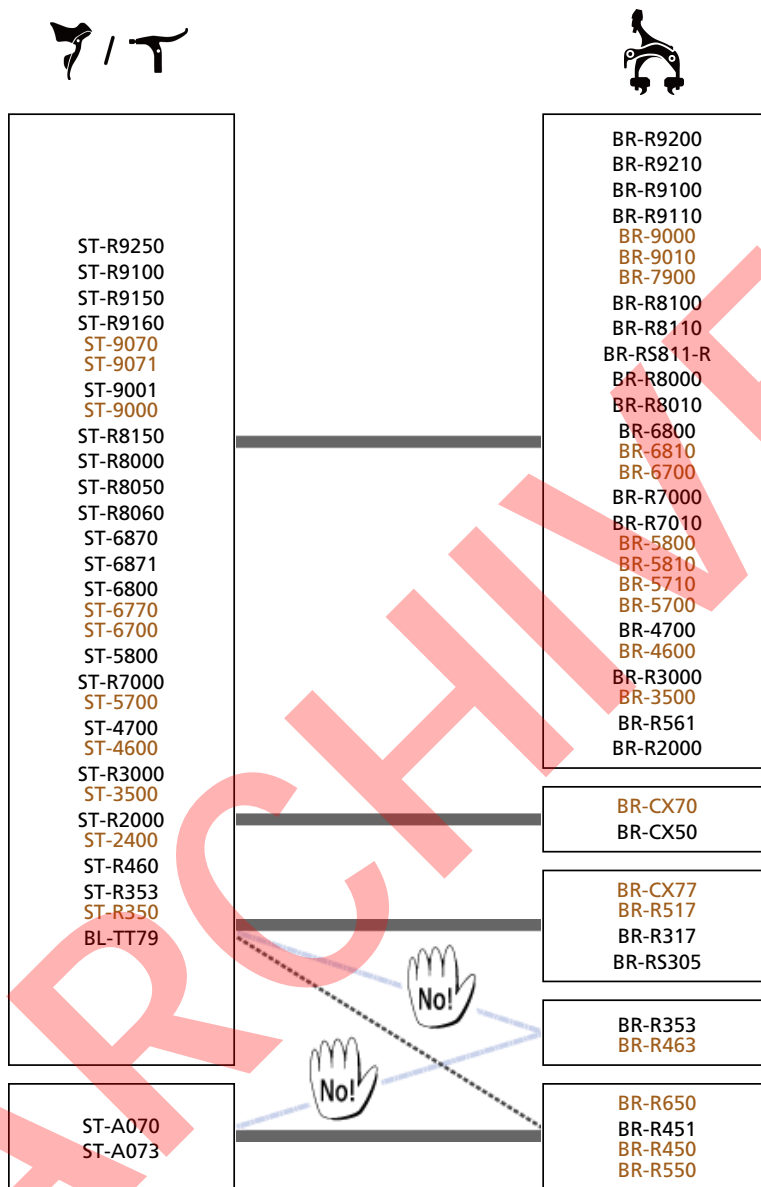

.....: Braking power is slightly less than standard combination.

: The "NO!" symbols indicate combinations that should not be used under any circumstances.

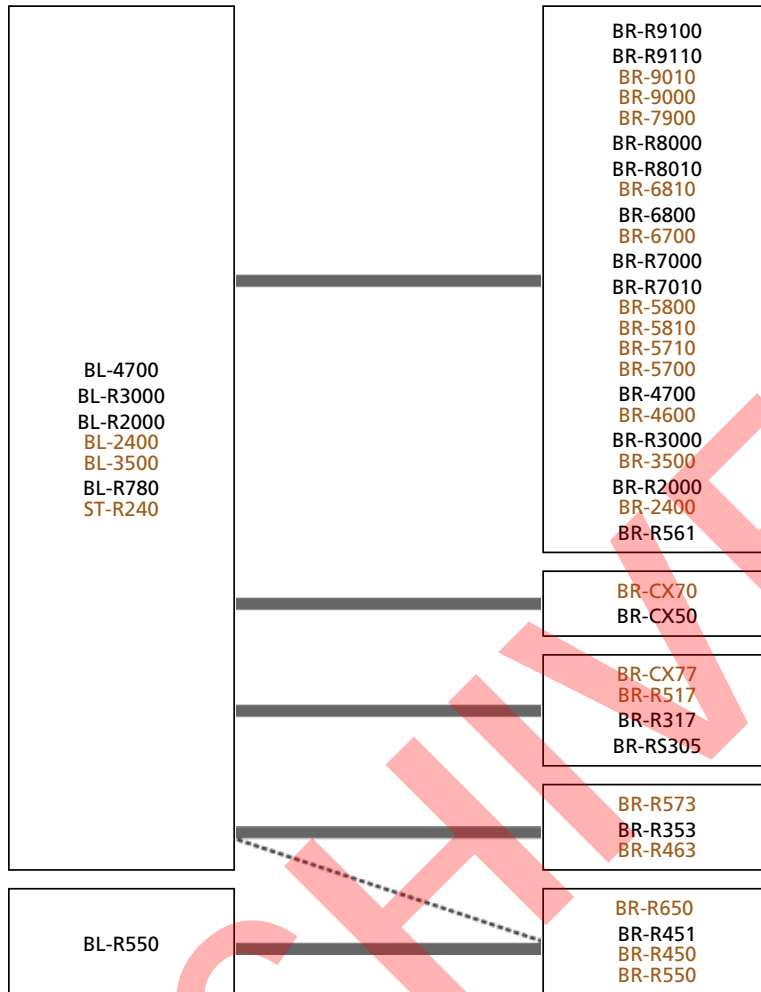

-----: Braking power is slightly less than standard combination.

ARCHIVE

Hydraulic systems compatibility [ROAD, Gravel]

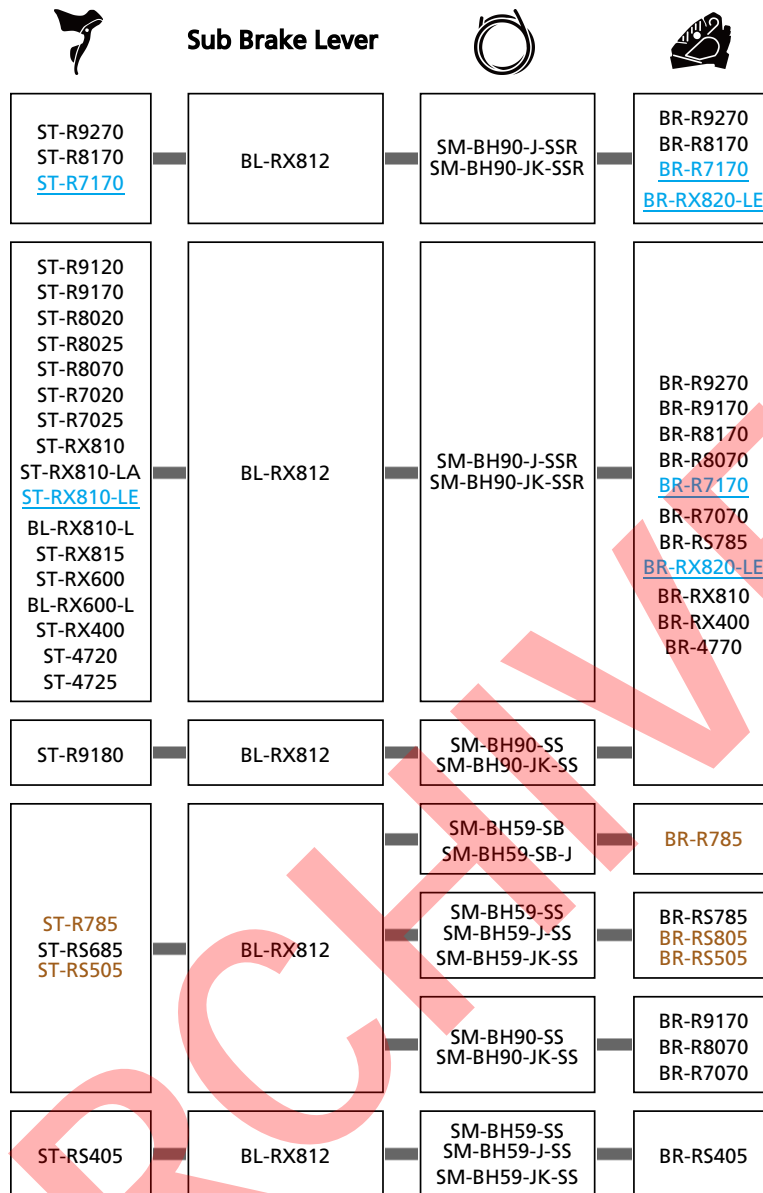

Hydraulic systems compatibility [URBAN]

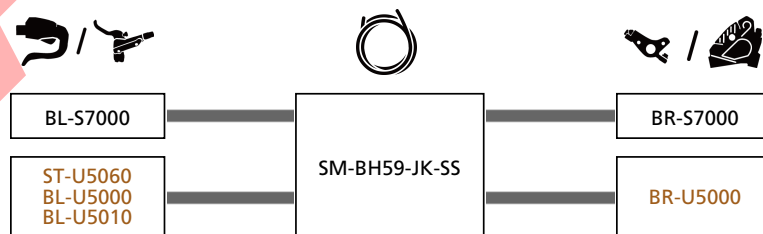

Compatibility of I-SPEC shifter and brake lever

C-157

Clamp band type shifter can be compatible as I-SPEC when you change upper body with integration unit.
(Exclude RAPIDFIRE PLUS MONO shift lever)

I-SPEC EV shift lever

	Model No.	SL-M9100-I	SL-M8100-I	SL-M7100-I	SL-M6100-I	SL-M5100-I	SL-M4100-I	SL-M8130-I
I-SPEC EV	BL-M9100	✓	✓	✓	✓	✓	✓	✓
	BL-M9120	✓	✓	✓	✓	✓	✓	✓
	BL-M8100	✓	✓	✓	✓	✓	✓	✓
	BL-M7100	✓	✓	✓	✓	✓	✓	✓
	BL-M6100	✓	✓	✓	✓	✓	✓	✓
	BL-M4100	✓	✓	✓	✓	✓	✓	✓
I-SPEC II	BL-M9000	-	-	-	-	-	-	-
	BL-M9020	-	-	-	-	-	-	-
	BL-M8000	-	-	-	-	-	-	-
	BL-T8100	-	-	-	-	-	-	-
	BL-T8000	-	-	-	-	-	-	-
	BL-M7000	-	-	-	-	-	-	-
	BL-M6000	-	-	-	-	-	-	-
	BL-T6000	-	-	-	-	-	-	-
	BL-RS600	-	-	-	-	-	-	-
	BL-MT500	-	-	-	-	-	-	-
	BL-MT501	-	-	-	-	-	-	-
	BL-U5000	-	-	-	-	-	-	-
I-SPEC B	BL-M987	-	-	-	-	-	-	-
	BL-M988-B	-	-	-	-	-	-	-
	BL-M820-B	-	-	-	-	-	-	-
	BL-M640-B	-	-	-	-	-	-	-
	BL-T780-B	-	-	-	-	-	-	-
	BL-T675-B	-	-	-	-	-	-	-
	BL-T670-B	-	-	-	-	-	-	-
	BL-T610	-	-	-	-	-	-	-
	BL-M506	-	-	-	-	-	-	-
	BL-S700-B	-	-	-	-	-	-	-

I-SPEC II shift lever

	Model No.	SL-M9000-I	SL-M8000-I	SL-M7000-11-I SL-M7000-10-I	SL-U5000	SL-M6000-I	SL-RS700-I
I-SPEC EV	BL-M9100	-	-	-	-	-	-
	BL-M9120	-	-	-	-	-	-
	BL-M8100	-	-	-	-	-	-
	BL-M7100	-	-	-	-	-	-
	BL-M6100	-	-	-	-	-	-
	BL-M4100	-	-	-	-	-	-
I-SPEC II	BL-M9000	✓	✓	✓	✓	✓	✓
	BL-M9020	✓	✓	✓	✓	✓	✓
	BL-M8000	✓	✓	✓	✓	✓	✓
	BL-T8100	✓	✓	✓	✓	✓	✓
	BL-T8000	✓	✓	✓	✓	✓	✓
	BL-M7000	✓	✓	✓	✓	✓	✓
	BL-M6000	✓	✓	✓	✓	✓	✓
	BL-T6000	✓	✓	✓	✓	✓	✓
	BL-RS600	✓	✓	✓	✓	✓	✓
	BL-MT500	✓	✓	✓	✓	✓	✓
	BL-MT501	✓	✓	✓	✓	✓	✓
	BL-U5000	✓	✓	✓	✓	✓	✓
I-SPEC B	BL-M987	-	-	-	-	-	-
	BL-M988-B	-	-	-	-	-	-
	BL-M820-B	-	-	-	-	-	-
	BL-M640-B	-	-	-	-	-	-
	BL-T780-B	-	-	-	-	-	-
	BL-T675-B	-	-	-	-	-	-
	BL-T670-B	-	-	-	-	-	-
	BL-T610	-	-	-	-	-	-
	BL-M506	-	-	-	-	-	-
	BL-S700-B	-	-	-	-	-	-

I-SPEC B shift lever

	Model No.	SL-M8000-B-I	SL-M7000-11 SL-M7000-10-B-I	SL-M820-B-I SL-M820 (with SM-SL82-B)
I-SPEC EV	BL-M9100	-	-	-
	BL-M9120	-	-	-
	BL-M8100	-	-	-
	BL-M7100	-	-	-
	BL-M6100	-	-	-
	BL-M4100	-	-	-
I-SPEC II	BL-M9000	-	-	-
	BL-M9020	-	-	-
	BL-M8000	-	-	-
	BL-T8100	-	-	-
	BL-T8000	-	-	-
	BL-M7000	-	-	-
	BL-M6000	-	-	-
	BL-T6000	-	-	-
	BL-RS600	-	-	-
	BL-MT500	-	-	-
	BL-MT501	-	-	-
BL-U5000	-	-	-	
I-SPEC B	BL-M987	✓	✓	✓
	BL-M988-B	✓	✓	✓
	BL-M820-B	✓	✓	✓
	BL-M640-B	✓	✓	✓
	BL-T780-B	✓	✓	✓
	BL-T675-B	✓	✓	✓
	BL-T670-B	✓	✓	✓
	BL-T610	✓	✓	✓
	BL-M506	✓	✓	✓
BL-S700-B	✓	✓	✓	

Compatibility of seat post lever and brake lever

	Model No.	I-SPEC EV shift lever	
		SL-MT800	SL-MT500-I
I-SPEC EV	BL-M9100	✓	✓
	BL-M9120	✓	✓
	BL-M8100	✓	✓
	BL-M7100	✓	✓
	BL-M6100	✓	✓
	BL-M4100	✓	✓
I-SPEC II	BL-M9000	-	-
	BL-M9020	-	-
	BL-M8000	-	-
	BL-T8100	-	-
	BL-T8000	-	-
	BL-M7000	-	-
	BL-M6000	-	-
	BL-T6000	-	-
	BL-RS600	-	-
	BL-MT500	-	-
	BL-MT501	-	-
BL-U5000	-	-	
I-SPEC B	BL-M987	-	-
	BL-M988-B	-	-
	BL-M820-B	-	-
	BL-M640-B	-	-
	BL-T780-B	-	-
	BL-T675-B	-	-
	BL-T670-B	-	-
	BL-T610	-	-
	BL-M506	-	-
BL-S700-B	-	-	

Disc brake caliper and disc brake rotor compatibility

C-461

Brake caliper	Brake pad material	Pad type	Disc brake rotor				
			220 mm (LL)	203 mm (L)	180 mm (M)	160 mm (S)	140 mm (SS)
BR-M9100*4 BR-M9110*5 BR-M9120 BR-M8100 BR-M8110*6 BR-M8120 BR-M8000 BR-M8020 BR-M7100 BR-M7110*6 BR-M7120 BR-M6100 BR-M6120 BR-MT520 BR-MT420 BR-M820	Metal / Resin	Narrow	SM-RT66-LL SM-RT64-LL	RT-MT905-L RT-MT900-L SM-RT99-L RT-MT800-L SM-RT86-L SM-RT81-L SM-RT76-L SM-RT70-L SM-RT66-L SM-RT64-L SM-RT30-L*2 RT-EM910-L*1 RT-EM900-L*1 RT-EM810-L*1 RT-EM600-L*1 RT-EM300-L*1*2	RT-MT905-M RT-MT900-M SM-RT99-M RT-MT800-M SM-RT86-M SM-RT81-M SM-RT76-M SM-RT70-M SM-RT66-M SM-RT64-M SM-RT56-M*2 SM-RT54-M*2 SM-RT30-M*2 SM-RT26-M*2 SM-RT10-M*2 RT-EM910-M*1 RT-EM900-M*1 RT-EM810-M*1 RT-EM800-M*1 RT-EM600-M*1 RT-EM300-M*1*2	RT-CL900-160 RT-CL800-160 RT-MT900-S SM-RT900-S SM-RT800-S SM-RT99-S RT-MT800-S SM-RT86-S SM-RT81-S SM-RT76-S SM-RT70-S SM-RT66-S SM-RT64-S SM-RTC60 SM-RT56-S*2 SM-RT54-S*2 SM-RT30-S*2 SM-RT26-S*2 SM-RT10-S*2 RT-EM910-M*1 RT-EM900-S*1 RT-EM810-M*1 RT-EM800-S*1 RT-EM300-S*1*2	RT-CL900-140 RT-CL800-140 RT-MT900-SS SM-RT900-SS SM-RT99-SS SM-RT99-A-SS RT-MT800-SS SM-RT800-SS SM-RT81-SS SM-RT70-SS
BR-S700 BR-S7000	Resin	-					
BR-MT410	Resin	Wide	-	SM-RT30-L RT-EM300-L*1			
BR-T675 BR-T615 BR-M4050 BR-MT500 BR-M446 BR-MT400 BR-M3050 BR-M395 BR-M375 BR-MT200 BR-M365 BR-M315 BR-TX805 BR-UR300	Resin	Wide	-		SM-RT56-M SM-RT54-M SM-RT30-M SM-RT26-M SM-RT10-M RT-EM300-M*1	SM-RT56-S SM-RT54-S SM-RT30-S SM-RT26-S SM-RT10-S RT-EM300-S*1	-
BR-R9270*7 BR-R9170*3 BR-R8170 BR-R8070 BR-R7170 BR-R7070 BR-4770 BR-RS805 BR-R785 BR-RS785 BR-RS505 BR-RS405 BR-RS305 BR-RX820-LE BR-RX810 BR-RX400	Metal / Resin	Narrow	-	-	RT-MT905-M RT-MT900-M RT-MT800-M SM-RT99-M SM-RT86-M SM-RT81-M SM-RT76-M SM-RT70-M SM-RT66-M SM-RT64-M SM-RT56-M*2 SM-RT54-M*2 SM-RT30-M*2 SM-RT26-M*2 SM-RT10-M*2 RT-EM910-M*1 RT-EM900-M*1 RT-EM810-M*1 RT-EM800-M*1 RT-EM600-M*1 RT-EM300-M*1*2	RT-CL900-160 RT-CL800-160 RT-MT900-S SM-RT900-S SM-RT800-S SM-RT800-S SM-RT99-S SM-RT86-S SM-RT81-S SM-RT76-S SM-RT70-S SM-RT66-S SM-RT64-S SM-RT56-S*2 SM-RT54-S*2 SM-RT30-S*2 SM-RT26-S*2 SM-RT10-S*2 RT-EM910-S*1 RT-EM810-S*1 RT-EM900-S*1 RT-EM810-S*1 RT-EM800-S*1 RT-EM600-S*1 RT-EM300-S*1*2	RT-CL900-140 RT-CL800-140 RT-MT900-SS SM-RT900-SS RT-MT800-SS SM-RT800-SS SM-RT99-SS SM-RT99-A-SS SM-RT81-SS SM-RT70-SS SM-RT64-SS
BR-CX77 BR-R517 BR-R317	Metal / Resin	Narrow	-	-	-	SM-RT99-S SM-RT86-S SM-RT81-S SM-RT76-S SM-RT70-S SM-RT66-S SM-RT64-S	SM-RT99-SS SM-RT99-A-SS SM-RT81-SS
BR-U5000*3	Metal / Resin	Narrow	-	-	-	SM-RT99-S SM-RT86-S SM-RT81-S SM-RT76-S SM-RT70-S SM-RT66-S SM-RT64-S	SM-RT500-SS SM-RT99-SS SM-RT99-A-SS SM-RT81-SS

- *1 Disc brake rotor for speed sensor SM-DUE11, rear only
- *2 Resin pad only
- *3 Not compatible with rear 180 mm (M) disc brake rotors
- *4 Not compatible with 220mm (LL) and 203 mm (L) disc brake rotors
- *5 For rear only. Not compatible with 220mm (LL), 203 mm (L) and 180 mm (M) disc brake rotors.
- *6 For rear only. Not compatible 220mm (LL) and with 203 mm (L) disc brake rotors.
- *7 Not compatible with 180 mm (M) disc brake rotors.

Wide type disc brake rotor

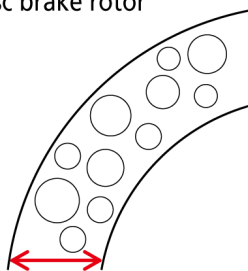

Narrow type disc brake rotor

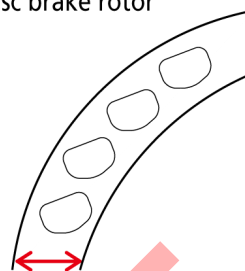

NOTE

- SM-RT56 / SM-RT54 / SM-RT30 / SM-RT26 / SM-RT10 / RT-EM300 are compatible with Resin pad caliper specification only. If use with metal pads, disc brake rotor will be easily damaged.
- When using 140 mm disc brake rotor, braking power is less than 160 mm, please confirm the power is enough for your purpose. 140 mm disc brake rotor is recommended for rear use only.
- Narrow type 2 piece disc brake rotors are not compatible to brake caliper for Wide type disc brake rotor because of interference.
- BR-UR300 doesn't need front mount bracket and rear adapter.

ARCHIVE

Compatibility of lock ring with hubs

C-612

Front hub (Disc Brake)

Type	Fixing type of lock ring		
	Internal spline	both Internal & external spline	External spline
QR type	✓	✓	✓
12 mm E-THRU type	✓	✓*	✓
15 mm E-THRU type	-	✓*	✓
20 mm thru axle type	-	✓*	✓

* For E-THRU hub, "Internal & external spline" type lock ring can not be install by TL-LR11. Please Tighten with TL-FC36.

FREEHUB (Disc Brake)

Model No.	Fixing type of lock ring		
	Internal spline	Internal & external spline	External spline
FH-M9111 FH-M9111-B FH-M9111-BS FH-M9000 FH-M9010 FH-M9010-B FH-MT901-B FH-MT901-BS	-	-	✓
Other models (MTB, Trekking, ROAD, URBAN)	✓	✓	✓

Compatibility between brake systems (MT400 series)

C-606

	BR-MT400	BR-MT420
BL-MT400	✓	-
BL-MT402-3A	✓	✓
BL-MT401-3A	✓	-
BL-MT401	✓	✓

Combination chart (mechanical disc brake)

C-462

Mechanical disc brake combination chart C-463

In order to realize the best performance, we recommend that the following combination be used.

Model No.	Mount type	Brake lever
BR-M375 BR-TX805	*	V-BRAKE BL (2 finger)
BR-R517	*	Road lever**
BR-R317	*	Road lever**
BR-CX77	*	Road lever**
BR-RS305	FLAT MOUNT	Road lever**

* Front mount: International standard / Post mount, Rear mount: International standard / Post mount

** For BL-R780 / 4600 / 5700

Mechanical disc brake and brake lever compatibility C-464

Model No.	Brake lever type		
	2 finger	3,4 finger	3,4 finger w/ POWER MODULATOR* w/ SM-PM50
BR-M375	✓	-	✓
BR-TX805	✓	-	✓

* POWER MODULATOR must be used for front brake

Compatibility between hydraulic disc brake hose

MTB / Trekking / URBAN C-732

Connection		SM-BH90-JK-SSR	SM-BH90-SBM	SM-BH90-SBLS	SM-BH90-SBS	SM-BH90-SB	SM-BH90-SS
Rigidity		Straight - Straight	Straight - Banjo	Straight - Banjo	Straight - Banjo	Straight - Banjo	Straight - Straight
		High power	High power	High power	High power	High power	High power
BL-M9100	BR-M9100	-	-	-	-	-	✓
BL-M9100	BR-M9110	-	-	-	-	-	✓
BL-M9120	BR-M9120	-	✓	-	-	-	-
BL-M9000	BR-M9000	-	✓	-	-	-	-
BL-M9020	BR-M9020	-	✓	-	-	✓	-
BL-M820	BR-M820	-	-	✓	-	-	-
BL-M8100	BR-M8100	-	✓	-	-	-	-
BL-M8100	BR-M8110	-	-	-	-	-	✓
BL-M8100	BR-M8120	-	✓	-	-	-	-
BL-M8000	BR-M8000	-	✓	-	-	✓	-
BL-M8000	BR-M8020	-	-	✓	-	-	-
BL-T8100	BR-M8100	-	✓	-	-	-	-
BL-T8100	BR-M8120	-	✓	-	-	-	-
BL-M7100	BR-M7100	-	✓	-	-	-	-
BL-M7100	BR-M7110	-	-	-	-	-	✓
BL-M7100	BR-M7120	-	✓	-	-	-	-
BL-M7000	BR-M7000	-	✓	-	-	✓	-
BL-M6100	BR-M6100	-	-	-	-	-	✓
BL-M6100	BR-M6120	-	-	-	-	-	✓
BL-T675	BR-T675	-	-	-	-	-	✓
BL-M640	BR-M640	-	-	✓	✓	-	-
BL-M6000	BR-M6000	-	-	-	-	-	✓
BL-M4100	BR-MT410	-	-	-	-	-	-
BL-M4100	BR-MT420	-	-	-	-	-	✓
BL-T6000	BR-M6000	-	-	-	-	-	-
BL-S7000	BR-S7000	-	-	-	-	-	-
BL-MT501	BR-MT520	-	-	-	-	-	✓
BL-MT501	BR-MT500	-	-	-	-	-	-
BL-MT500	BR-MT500	-	-	-	-	-	-
ST-M4050	BR-M4050	-	-	-	-	-	-
ST-M3050	BR-M3050	-	-	-	-	-	-
BL-T445	BR-M446	-	-	-	-	-	-
BL-MT400	BR-MT400	-	-	-	-	-	-
BL-MT401	BR-MT400	-	-	-	-	-	-
BL-MT401	BR-MT420	-	-	-	-	-	✓
BL-MT401-3A	BR-MT400	-	-	-	-	-	-
BL-MT402-3A	BR-MT400	-	-	-	-	-	-
BL-MT402-3A	BR-MT420	-	-	-	-	-	✓
BL-M425	BR-M395	-	-	-	-	-	-
BL-M396	BR-M395	-	-	-	-	-	-
BL-MT201	BR-MT200	-	-	-	-	-	-
BL-MT200	BR-MT200	-	-	-	-	-	-
BL-MT201	BR-UR300	-	-	-	-	-	-
BL-MT200	BR-UR300	-	-	-	-	-	-
BL-M365	BR-M365	-	-	-	-	-	-
BL-M315	BR-M315	-	-	-	-	-	-
ST-EF505	BR-M315	-	-	-	-	-	-
ST-EF505	BR-MT200	-	-	-	-	-	-
BL-S700	BR-S700	-	✓	-	-	✓	-
BL-U5000	BR-U5000	-	-	-	-	-	-
BL-U5010	BR-U5000	-	-	-	-	-	-
ST-U5060	BR-U5000	-	-	-	-	-	-

		SM-BH59-J-SS	SM-BH59-JK-SS (MTB)	SM-BH59-JK-SS (ROAD)	SM-BH59-SB	SM-BH59-SB-J
Connection		Straight - Straight	Straight - Straight	Straight - Straight	Straight - Banjo	Straight - Banjo
Rigidity		Standard	Standard	Standard	Standard	Standard
BL-M9100	BR-M9100	-	-	-	-	-
BL-M9100	BR-M9110	-	-	-	-	-
BL-M9120	BR-M9120	-	-	-	-	-
BL-M9000	BR-M9000	-	-	-	-	-
BL-M9020	BR-M9020	-	-	-	-	-
BL-M820	BR-M820	-	-	-	-	-
BL-M8100	BR-M8100	-	-	-	-	-
BL-M8100	BR-M8110	-	-	-	-	-
BL-M8100	BR-M8120	-	-	-	-	-
BL-M8000	BR-M8000	-	-	-	-	-
BL-M8000	BR-M8020	-	-	-	-	-
BL-T8100	BR-M8100	-	-	-	-	-
BL-T8100	BR-M8120	-	-	-	-	-
BL-M7100	BR-M7100	-	-	-	-	-
BL-M7100	BR-M7110	-	-	-	-	-
BL-M7100	BR-M7120	-	-	-	-	-
BL-M7000	BR-M7000	-	-	-	-	-
BL-M6100	BR-M6100	-	-	-	-	-
BL-M6100	BR-M6120	-	-	-	-	-
BL-T675	BR-T675	-	-	-	-	-
BL-M640	BR-M640	-	-	-	-	-
BL-M6000	BR-M6000	-	-	-	-	-
BL-M4100	BR-MT410	-	✓	-	-	-
BL-M4100	BR-MT420	-	-	-	-	-
BL-T6000	BR-M6000	-	✓	-	-	-
BL-S7000	BR-S7000	-	✓	-	-	-
BL-MT501	BR-MT520	-	-	-	-	-
BL-MT501	BR-MT500	-	✓	-	-	-
BL-MT500	BR-MT500	-	✓	-	-	-
ST-M4050	BR-M4050	-	✓	-	-	-
ST-M3050	BR-M3050	-	✓	-	-	-
BL-T445	BR-M446	-	✓	-	-	-
BL-MT400	BR-MT400	-	✓	-	-	-
BL-MT401	BR-MT400	-	✓	-	-	-
BL-MT401	BR-MT420	-	-	-	-	-
BL-MT401-3A	BR-MT400	-	✓	-	-	-
BL-MT402-3A	BR-MT400	-	✓	-	-	-
BL-MT402-3A	BR-MT420	-	-	-	-	-
BL-M425	BR-M395	-	✓	-	-	-
BL-M396		-		-	-	-
BL-MT201	BR-MT200	-	✓	-	-	-
BL-MT200	BR-MT200	-	✓	-	-	-
BL-MT201	BR-UR300	-	✓	-	-	-
BL-MT200	BR-UR300	-	✓	-	-	-
BL-M365	BR-M365	-	✓	-	-	-
BL-M315	BR-M315	-	✓	-	-	-
ST-EF505	BR-M315	-	✓	-	-	-
ST-EF505	BR-MT200	-	✓	-	-	-
BL-S700	BR-S700	-	-	-	-	-
BL-U5000		-	-	✓	-	-
BL-U5010	BR-U5000	-	-	✓	-	-
ST-U5060		-	-	✓	-	-

Level of compatibility

✓: Compatible

*: Refer to manual of SM-BH80, SM-BH59 (brake hose 10 m coil) for assembling / disassembling banjo unit

-: Impossible to use

ROAD / Gravel c-733

Connection		SM-BH90-JK-SSR	SM-BH90-SBM	SM-BH90-SBLS	SM-BH90-SBS	SM-BH90-SB	SM-BH90-SS
Rigidity		Straight - Straight	Straight - Banjo	Straight - Banjo	Straight - Banjo	Straight - Banjo	Straight - Straight
Rigidity		High power	High power	High power	High power	High power	High power
ST-R9270	BR-R9270	✓	-	-	-	-	-
ST-R9120	BR-R9170	✓	-	-	-	-	-
ST-R9170	BR-R9170	✓	-	-	-	-	-
ST-R9180	BR-R9170	✓	-	-	-	-	-
ST-R8170	BR-R8170	✓	-	-	-	-	-
ST-R8020	BR-R8070	✓	-	-	-	-	-
ST-R8070	BR-R8070	✓	-	-	-	-	-
ST-R7170	BR-R7170	✓	-	-	-	-	-
ST-R7020	BR-R7070	✓	-	-	-	-	-
ST-R7025	BR-R7070	✓	-	-	-	-	-
ST-R785	BR-RS805	-	-	-	-	-	-
ST-R785	BR-RS785	-	-	-	-	-	-
ST-R785	BR-R785	-	-	-	-	-	-
ST-RS685	BR-RS805	-	-	-	-	-	-
ST-RS685	BR-RS785	-	-	-	-	-	-
ST-RS685	BR-R785	-	-	-	-	-	-
ST-RS505	BR-RS785	-	-	-	-	-	-
ST-RS505	BR-RS505	-	-	-	-	-	-
ST-RS405	BR-RS405	-	-	-	-	-	-
BL-RS600	BR-RS405	-	-	-	-	-	-
ST-RX810-LE	BR-RX820-LE	✓	-	-	-	-	-
BL-T8100-LE	BR-RX820-LE	-	-	-	-	-	✓
ST-RX815	BR-RX810	✓	-	-	-	-	-
ST-RX810	BR-RX810	✓	-	-	-	-	-
BL-RX810	BR-RX810	✓	-	-	-	-	-
ST-RX600	BR-RX400	✓	-	-	-	-	-
BL-RX600	BR-RX400	✓	-	-	-	-	-
ST-RX400	BR-RX400	✓	-	-	-	-	-

Connection		SM-BH59-J-SS	SM-BH59-JK-SS (MTB)	SM-BH59-JK-SS (ROAD)	SM-BH59-SB	SM-BH59-SB-J
Rigidity		Straight - Straight	Straight - Straight	Straight - Straight	Straight - Banjo	Straight - Banjo
Rigidity		Standard	Standard	Standard	Standard	Standard
ST-R9270	BR-R9270	-	-	-	-	-
ST-R9120	BR-R9170	-	-	-	-	-
ST-R9170	BR-R9170	-	-	-	-	-
ST-R9180	BR-R9170	-	-	-	-	-
ST-R8170	BR-R8170	-	-	-	-	-
ST-R8020	BR-R8070	-	-	-	-	-
ST-R8070	BR-R8070	-	-	-	-	-
ST-R7170	BR-R7170	-	-	-	-	-
ST-R7020	BR-R7070	-	-	-	-	-
ST-R7025	BR-R7070	-	-	-	-	-
ST-R785	BR-RS805	✓	-	-	-	-
ST-R785	BR-RS785	✓	-	-	-	-
ST-R785	BR-R785	-	-	-	✓	✓
ST-RS685	BR-RS805	✓	-	✓	-	-
ST-RS685	BR-RS785	✓	-	✓	-	-
ST-RS685	BR-R785	-	-	-	✓	✓
ST-RS505	BR-RS785	✓	-	✓	-	-
ST-RS505	BR-RS505	✓	-	✓	-	-
ST-RS405	BR-RS405	-	-	✓	-	-
BL-RS600	BR-RS405	-	✓	-	-	-
ST-RX810-LE	BR-RX820-LE	-	-	-	-	-
BL-T8100-LE	BR-RX820-LE	-	-	-	-	-
ST-RX815	BR-RX810	-	-	-	-	-
ST-RX810	BR-RX810	-	-	-	-	-
BL-RX810	BR-RX810	-	-	-	-	-
ST-RX600	BR-RX400	-	-	-	-	-
BL-RX600	BR-RX400	-	-	-	-	-
ST-RX400	BR-RX400	-	-	-	-	-

Level of compatibility

✓: Compatible



*: Refer to manual of SM-BH80, SM-BH59 (brake hose 10 m coil) for assembling / disassembling banjo unit

-: Impossible to use

Banjo screw	Special	Normal	Short	BR-M9120 SPEC.	BR-M8100 SPEC.
BR-M9120	-	-	-	✓	-
BR-M9000	✓	-	-	-	-
BR-M9020	✓	✓	-	-	-
BR-M820	-	-	✓	-	✓
BR-M8100	-	-	-	-	✓
BR-M8120	-	-	-	✓	-
BR-M8000	✓	✓	-	-	-
BR-M8020	-	-	✓	-	-
BR-M7100	-	-	-	-	✓
BR-M7120	-	-	-	✓	-
BR-M7000	✓	✓	-	-	-
BR-M640	-	-	✓	-	✓
BR-S700	✓	✓	-	-	-
BR-R785	✓	✓	-	-	-

Brake pad line-up

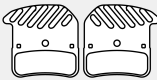
Brake pad for hydraulic disc brake (4-piston) C-652

Pad Shape Type							
		D-type		H-type		N-type	
Type		Narrow type		Narrow type		Narrow type	
		D03S-RX Resin	D02S-MX Metal	H03A-RF Resin	H03C-MF Metal	N03A-RF Resin	N04C-MF Metal
Characteristics	Modulation	★★★★★	★★★★☆	★★★★★	★★★★☆	★★★★★	★★★★☆
	Power	★★★★☆	★★★★★	★★★★☆	★★★★★	★★★★☆	★★★★★
	Durability	★★★★★	★★★★★	★★★★★	★★★★★	★★★★★	★★★★★
	Anti-fading	★★★★☆	★★★★★	★★★★☆	★★★★★	★★★★☆	★★★★★
	Silence	★★★★★	★★★★☆	★★★★★	★★★★☆	★★★★★	★★★★☆
Pad Radiator fin		-	-	✓	✓	✓	✓
High heat insulation		-	-	-	-	-	-
Pad Back plate	Titanium	-	-	-	-	-	-
	Aluminum	-	-	✓	-	✓	-
	Stainless steel/ Aluminum	-	-	-	✓	-	✓
	Stainless steel	✓	✓	-	-	-	-
BR-M9120	Hydraulic	Option	Option	-	-	Standard	Standard
BR-M8120	Hydraulic	Option	Option	-	-	Standard	Standard
BR-M7120	Hydraulic	Standard	Option	-	-	Standard	Option
BR-M6120	Hydraulic	Standard	Option	-	-	-	-
BR-MT520	Hydraulic	Standard	Standard	-	-	-	-
BR-MT420	Hydraulic	Standard	Standard	-	-	-	-
BR-M8020	Hydraulic	Option	-	Standard	Option	-	-
BR-M820	Hydraulic	-	-	Standard	Standard	-	-

Brake pad for hydraulic disc brake (2-piston) and mechanical disc brake

C-653

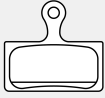
Pad Shape Type									
		B-type		G-type					
		Wide type		Narrow type					
Type		B03S-RX	B05S-RX	G03A-RX	G05A-RX	G03S-RX	G05S-RX	G04S-MX	G04Ti-MX
		Resin	Resin	Resin	Resin	Resin	Resin	Metal	Metal
Characteristics	Modulation	★★★★★	★★★★★	★★★★★	★★★★★	★★★★★	★★★★★	★★★★☆	★★★★☆
	Power	★★★★☆	★★★★☆	★★★★☆	★★★★☆	★★★★☆	★★★★☆	★★★★★	★★★★★
	Durability	★★★★★	★★★★★*1	★★★★★	★★★★★*1	★★★★★	★★★★★*1	★★★★★	★★★★★
	Anti-fading	★★★☆☆	★★★☆☆	★★★☆☆	★★★☆☆	★★★☆☆	★★★☆☆	★★★★★	★★★★★
	Silence	★★★★★	★★★★★	★★★★★	★★★★★	★★★★★	★★★★★	★★★★☆	★★★★☆
Pad Radiator fin		-	-	-	-	-	-	-	-
High heat insulation		-	-	✓	✓	✓	✓	-	-
Pad Back plate	Titanium	-	-	-	-	-	-	-	✓
	Aluminum	-	-	✓	✓	-	-	-	-
	Stainless steel/ Aluminum	-	-	-	-	-	-	-	-
	Stainless steel	✓	✓	-	-	✓	✓	✓	-
BR-M9100	Hydraulic	-	-	-	-	-	-	-	-
BR-M9110	Hydraulic	-	-	-	-	-	-	-	-
BR-M8100	Hydraulic	-	-	Standard	Standard	-	-	Standard	-
BR-M8110	Hydraulic	-	-	-	-	-	-	-	-
BR-M7100	Hydraulic	-	-	-	-	Standard	Standard	Standard	-
BR-M7110	Hydraulic	-	-	-	-	-	-	-	-
BR-M8000	Hydraulic	-	-	Standard	Standard	-	-	Option	-
BR-M6100	Hydraulic	-	-	-	-	Standard	Standard	Option	-
BR-M6000	Hydraulic	-	-	Standard	Standard	-	-	Option	-
BR-MT500	Hydraulic	Standard	Standard	-	-	-	-	-	-
BR-MT400	Hydraulic	Standard	Standard	-	-	-	-	-	-
BR-MT410	Hydraulic	Standard	Standard	-	-	-	-	-	-
BR-MT200	Hydraulic	Standard	Standard	-	-	-	-	-	-
BR-M375	Mechanical	Standard	Standard	-	-	-	-	-	-
BR-TX805	Mechanical	Standard	Standard	-	-	-	-	-	-
BR-R9270	Hydraulic	-	-	-	-	-	-	-	-
BR-R9170	Hydraulic	-	-	-	-	-	-	-	-
BR-R8170	Hydraulic	-	-	-	-	-	-	-	-
BR-R8070	Hydraulic	-	-	-	-	-	-	-	-
BR-R7170	Hydraulic	-	-	-	-	-	-	-	-
BR-R7070	Hydraulic	-	-	-	-	-	-	-	-
BR-4770	Hydraulic	-	-	-	-	-	-	-	-
BR-RS785	Hydraulic	-	-	Option	Option	-	-	-	-
BR-RS405	Hydraulic	-	-	-	-	-	-	-	-
BR-RX820-LE	Hydraulic	-	-	-	-	-	-	-	-
BR-RX810	Hydraulic	-	-	-	-	-	-	-	-
BR-RX400	Hydraulic	-	-	-	-	-	-	-	-
BR-UR300	Hydraulic	Standard	Standard	-	-	-	-	-	-
BR-S7000	Hydraulic	-	-	-	-	Standard	-	-	-
BR-RS305	Mechanical	-	-	-	-	-	-	-	-
BR-R317	Mechanical	-	-	Standard	Standard	-	-	-	-

*1 "05" pad is more durable than "03" pad in the same type by 40%

Pad Shape Type							
		K-type					
Type		Narrow type					
		K03S-RX	K05S-RX	K03Ti-RX	K05Ti-RX	K04S-MX	K04Ti-MX
Type		Resin	Resin	Resin	Resin	Metal	Metal
Characteristics	Modulation	★★★★★	★★★★★	★★★★★	★★★★★	★★★★☆	★★★★☆
	Power	★★★★☆	★★★★☆	★★★★☆	★★★★☆	★★★★★	★★★★★
	Durability	★★★★★	★★★★★*1	★★★★★	★★★★★*1	★★★★★	★★★★★
	Anti-fading	★★★☆☆	★★★☆☆	★★★☆☆	★★★☆☆	★★★★★	★★★★★
	Silence	★★★★★	★★★★★	★★★★★	★★★★★	★★★☆☆	★★★☆☆
Pad Radiator fin		-	-	-	-	-	-
High heat insulation		✓	✓	✓	✓	-	-
Pad Back plate	Titanium	-	-	✓	✓	-	✓
	Aluminum	-	-	-	-	-	-
	Stainless steel/ Aluminum	-	-	-	-	-	-
	Stainless steel	✓	✓	-	-	✓	-
BR-M9100	Hydraulic	-	-	Standard	Standard	-	Standard
BR-M9110	Hydraulic	-	-	Standard	Standard	-	Standard
BR-M8100	Hydraulic	-	-	-	-	-	-
BR-M8110	Hydraulic	Standard	Standard	-	-	Standard	-
BR-M7100	Hydraulic	-	-	-	-	-	-
BR-M7110	Hydraulic	Standard	Standard	-	-	Standard	-
BR-M8000	Hydraulic	-	-	-	-	-	-
BR-M6100	Hydraulic	-	-	-	-	-	-
BR-M6000	Hydraulic	-	-	-	-	-	-
BR-MT500	Hydraulic	-	-	-	-	-	-
BR-MT400	Hydraulic	-	-	-	-	-	-
BR-MT410	Hydraulic	-	-	-	-	-	-
BR-MT200	Hydraulic	-	-	-	-	-	-
BR-M375	Mechanical	-	-	-	-	-	-
BR-TX805	Mechanical	-	-	-	-	-	-
BR-R9270	Hydraulic	-	-	Standard	Standard	-	Option
BR-R9170	Hydraulic	-	-	Standard	Standard	-	Option
BR-R8170	Hydraulic	Standard	Standard	-	-	-	-
BR-R8070	Hydraulic	Standard	Standard	-	-	Option	-
BR-R7170	Hydraulic	Standard	Standard	-	-	-	-
BR-R7070	Hydraulic	Standard	Standard	-	-	Option	-
BR-4770	Hydraulic	Standard	Standard	-	-	Standard	-
BR-R5785	Hydraulic	-	-	-	-	-	-
BR-RS405	Hydraulic	Standard	Standard	-	-	-	-
BR-RX820-LE	Hydraulic	Standard	Standard	-	-	-	-
BR-RX810	Hydraulic	Standard	Standard	-	-	Option	-
BR-RX400	Hydraulic	Standard	Standard	-	-	Option	-
BR-UR300	Hydraulic	-	-	-	-	-	-
BR-S7000	Hydraulic	-	-	-	-	-	-
BR-RS305	Mechanical	Standard	Standard	-	-	-	-
BR-R317	Mechanical	-	-	-	-	-	-

*1 "05" pad is more durable than "03" pad in the same type by 40%

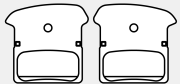
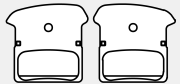
Pad Shape Type							
		F-type			L-type		
Type		Narrow type			Narrow type		
		J03A-RF Resin	J05A-RF Resin	J04C-MF Metal	L03A-RF Resin	L05A-RF Resin	L04C-MF Metal
Characteristics	Modulation	★★★★★	★★★★★	★★★★☆	★★★★★	★★★★★	★★★★☆
	Power	★★★★☆	★★★★☆	★★★★★	★★★★☆	★★★★☆	★★★★★
	Durability	★★★★★	★★★★★*1	★★★★★	★★★★★	★★★★★*1	★★★★★
	Anti-fading	★★★★☆	★★★★☆	★★★★★	★★★★☆	★★★★☆	★★★★★
	Silence	★★★★★	★★★★★	★★★★☆	★★★★★	★★★★★	★★★★☆
Pad Radiator fin		✓	✓	✓	✓	✓	✓
High heat insulation		✓	✓	-	✓	✓	-
Pad Back plate	Titanium	-	-	-	-	-	-
	Aluminum	✓	✓	-	✓	✓	-
	Stainless steel/ Aluminum	-	-	✓	-	-	✓
	Stainless steel	-	-	-	-	-	-
BR-M9100	Hydraulic	-	-	-	-	-	-
BR-M9110	Hydraulic	-	-	-	-	-	-
BR-M8100	Hydraulic	Option	Option	Option	-	-	-
BR-M8110	Hydraulic	-	-	-	Option	Option	Option
BR-M7100	Hydraulic	Option	Option	Option	-	-	-
BR-M7110	Hydraulic	-	-	-	Option	Option	Option
BR-M8000	Hydraulic	Standard	Standard	Option	-	-	-
BR-M6100	Hydraulic	Standard	Standard	-	-	-	-
BR-M6000	Hydraulic	Standard	Standard	-	-	-	-
BR-MT500	Hydraulic	-	-	-	-	-	-
BR-MT400	Hydraulic	-	-	-	-	-	-
BR-MT410	Hydraulic	-	-	-	-	-	-
BR-MT200	Hydraulic	-	-	-	-	-	-
BR-M375	Mechanical	-	-	-	-	-	-
BR-TX805	Mechanical	-	-	-	-	-	-
BR-R9270	Hydraulic	-	-	-	Standard	Standard	Option
BR-R9170	Hydraulic	-	-	-	Standard	Standard	Option
BR-R8170	Hydraulic	-	-	-	Standard	Standard	Option
BR-R8070	Hydraulic	-	-	-	Standard	Standard	Option
BR-R7170	Hydraulic	-	-	-	Standard	Standard	Option
BR-R7070	Hydraulic	-	-	-	Standard	Standard	Option
BR-4770	Hydraulic	-	-	-	Option	Option	-
BR-RS785	Hydraulic	Standard	Standard	Standard	-	-	-
BR-RS405	Hydraulic	-	-	-	Option	Option	-
BR-RX820-LE	Hydraulic	-	-	-	Standard	Standard	Option
BR-RX810	Hydraulic	-	-	-	Standard	Standard	Option
BR-RX400	Hydraulic	-	-	-	Standard	Standard	Option
BR-UR300	Hydraulic	-	-	-	-	-	-
BR-S7000	Hydraulic	-	-	-	-	-	-
BR-RS305	Mechanical	-	-	-	Option	Option	-
BR-R317	Mechanical	-	-	-	-	-	-

*1 "05" pad is more durable than "03" pad in the same type by 40%

How to read Model No. C-194

(1) (2) (3) (4) (5) (6)
SM-MA-F203S/P

(1)	Small parts
(2)	Mount adapter
(3)	F = Front and Rear * R = Rear
(4)	Disc brake rotor size **
(5)	Caliper mount type S = International A-standard P = Post D = Flat mount
(6)	Suspension / Frame type S = International A-standard P = Post D = Flat mount

NOTE

* This part may be used in the rear.

In this case, the disc brake rotor size description is also different. Refer to the table below.

** The disc brake rotor size description is 160 mm. Direct post mount/International A-standard forks and frames are supported. Refer to the table below for other mount types.

ARCHIVE

Application table for adapter C-195

For post mount brake caliper

Fork and frame mount type			Disc brake rotor size				
			140 mm (SS)	160 mm (S)	180 mm (M)	203 mm (L)	220 mm (LL)
Post mount	Front	140 mm direct	Direct mount	SM-MA90-F180P/P SM-MA-F180P/P2 (for R785)	-	-	-
		160 mm direct	-	Direct mount	SM-MA90-F180P/P SM-MA-F180P/P2	SM-MA-F203P/P	-
		180 mm direct	-	-	Direct mount	SM-MA90-F203P/PM SM-MA-F203P/PM	SM-MA-F220P/PM
		200 mm direct	-	-	-	SM-MA-F203P/PL2	SM-MA-F220P/PL2
		203 mm direct	-	-	-	Direct mount	SM-MA-F220P/PL
	Rear	140 mm direct	Direct mount	SM-MA90-F180P/P SM-MA-F180P/P2	-	-	-
		160 mm direct	-	Direct mount	SM-MA90-F180P/P SM-MA-F180P/P2	SM-MA-F203P/P	-
		180 mm direct	-	-	Direct mount	SM-MA90-F203P/PM SM-MA-F203P/PM	SM-MA-F220P/PM
		200 mm direct	-	-	-	SM-MA-F203P/PL2	SM-MA-F220P/PL2
		203 mm direct	-	-	-	Direct mount	SM-MA-F220P/PL
International A-standard	Front	-	SM-MA90-F160P/S SM-MA-F160P/S	SM-MA-F180P/S	SM-MA-F203P/S	-	
	Rear	SM-MA90-R140P/S	SM-MA90-R160P/S SM-MA-R160P/S	SM-MA90-R180P/S SM-MA-R180P/S	SM-MA-R203P/S	-	
Flat mount ø140/160	Front	SM-MA-F140P/D	SM-MA-F160P/D	-	-	-	
	Rear	SM-MA-R140P/D	SM-MA-R160P/D	-	-	-	
Flat mount ø160/180	Front	-	-	-	-	-	
	Rear	-	-	-	-	-	

For flat mount brake caliper

Fork and frame mount type			Disc brake rotor size		
			140 mm (SS)	160 mm (S)	180 mm (M)
Flat mount	ø140/160	Front	With Y8N230000* on product	With Y8N230000* on product	-
		Rear	Direct mount	SM-MA-R160D/D	-
	ø160/180	Front	-	With Y8N230000* on product	With Y8N230000* on product
		Rear	-	Direct mount	SM-MA-R160D/D
Flat mount BR-UR300	ø140/160	Front	-	Direct mount	-
		Rear	-	Direct mount	-
	ø160/180	Front	-	-	Direct mount
		Rear	-	-	Direct mount

* SHIMANO easy flip-flop bracket system which allow 1 bracket to be compatible with 2 rotor size.

Polymer-coated brake cable (BC-9000 / BC-R680) compatible chart

Series	Brake with polymer-coated brake cable	
DURA-ACE	BR-R9200	✓
	BR-R9210	
	BR-R9100	
	BR-R9110	
ULTEGRA	BR-R8100	✓
	BR-R8110	
	BR-RS811-R	
	BR-R8000	
SHIMANO 105	BR-R7000	✓
	BR-R7010	
	BR-5810	-
	BR-5700	-
TIAGRA	BR-4700	✓
SORA	BR-R3000	✓
CLARIS	BR-R2000	✓
Others		-

C-306





ARCHIVE

Compatibility between brake systems

C-466

Depending on the brake and brake lever combination to be used, the relationship between the input at the brake lever and the actual braking force output at the wheels is very easily affected.

Be very careful when combining a brake and brake lever. Incorrect combinations can cause accidents or insufficient braking forces due to improper cable strokes. Be sure to carefully consult the chart below and select the brake and the matching brake lever.

		V-BRAKE		Roller Brake
		BR-T780 BR-MX70 BR-R573 BR-R463 BR-R353 BR-T670 BR-T610 BR-T4010 BR-T4000	With POWER MODULATOR* model BR-T780 with SM-PM70 BR-T670 with SM-PM70 BR-T610 with SM-PM70 BR-T4010 with SM-PM40 BR-T4000 with SM-PM40 BR-R573 with SM-PM70 BR-R463 with SM-PM40 BR-R353 with SM-PM70	BR-C6060-F BR-C6050-F BR-C6000 BR-C3010 BR-C3000
V-BRAKE Levers (2-finger)				
ST-M4000 ST-EF41 ST-TX800 ST-M370 ST-M310 ST-EF510 ST-EF500 ST-EF65 ST-EF51	BL-T610 BL-M571 BL-T4000 BL-MX70	✓	✓	
V-BRAKE Levers (3-finger)				
ST-T4000 ST-T3000	BL-T780 BL-T611 BL-T670 BL-T780-B BL-T4010 BL-T670-B		✓	
Brake Levers with switch				
ST-R240	BL-4600 BL-R780 BL-4700 BL-R3000 BL-R2000 BL-2400	✓	✓	NOTE
V-BRAKE lever with switch				
ST-M310 (4-finger) ST-EF65 (4-finger) ST-EF510 (4-finger) ST-EF500 (4-finger) BL-C6000			✓	NOTE
	BL-C6010 SB-C6000-8 SB-C3000-7			✓

* POWER MODULATOR must be used for front brake



The "NO!" symbols indicate combinations that should not be used under any circumstances.

NOTE

This combination will not provide the sufficient amount of braking force.

Brake lever with switch compatibility

Four finger brake levers such as brake levers are equipped with a switch to change between the V-BRAKE with modulator mode (for example with SM-PM40) and the caliper brake or roller brake mode.

For V-BRAKE (with POWER MODULATOR) mode C-468

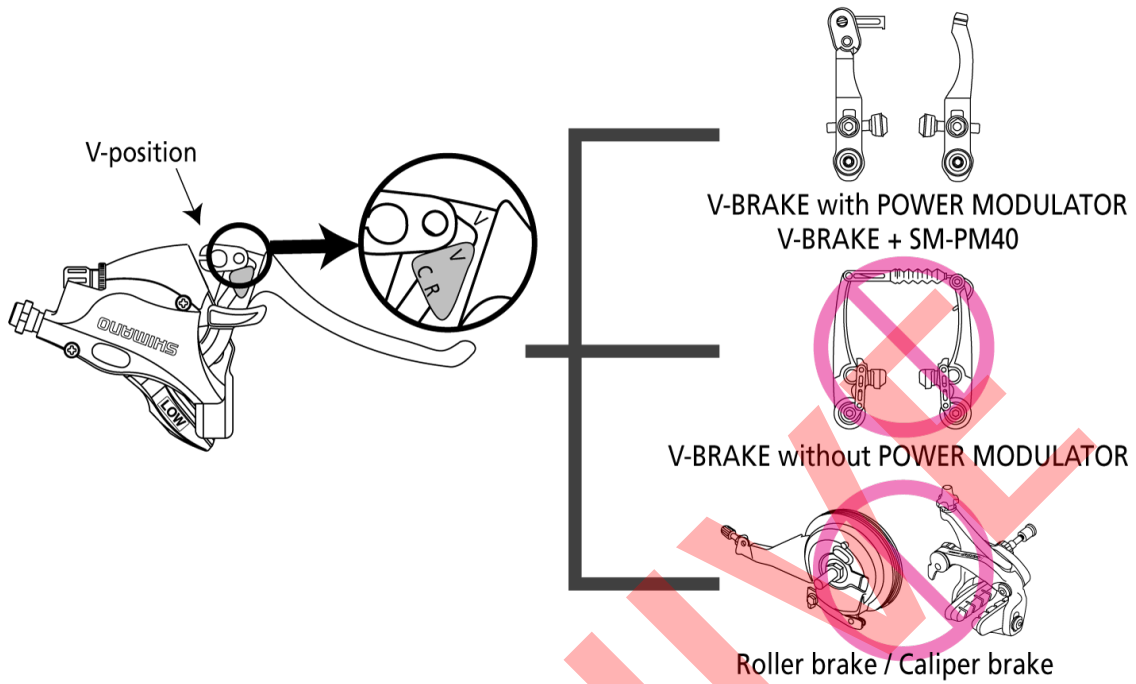

For Caliper brake / Roller brake C-469

BL-C6010

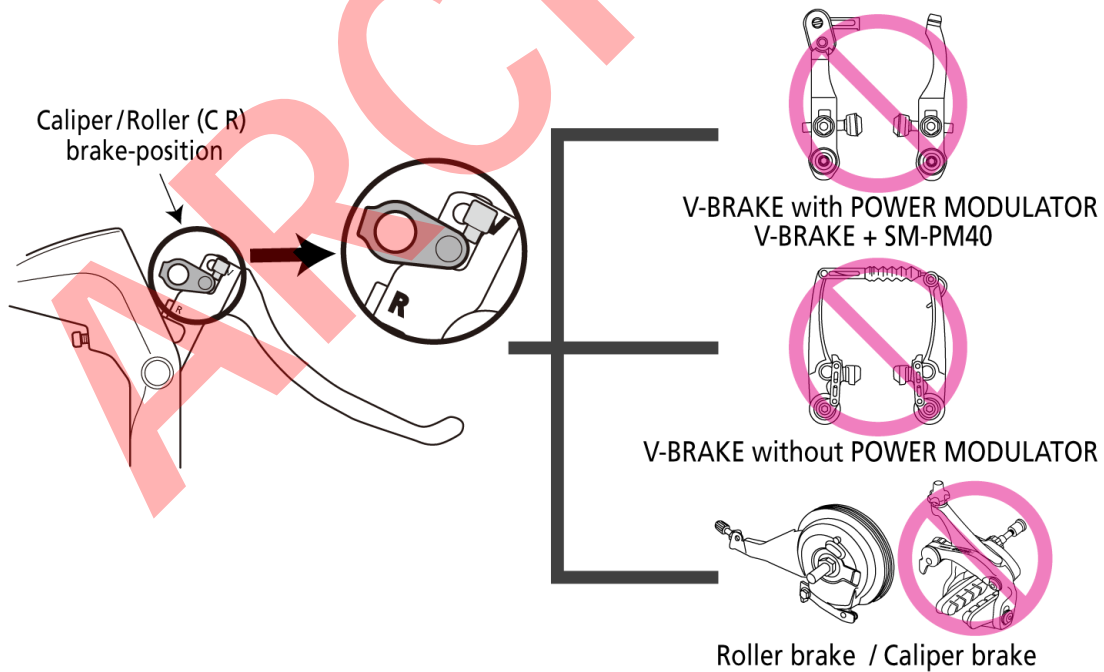

Other models

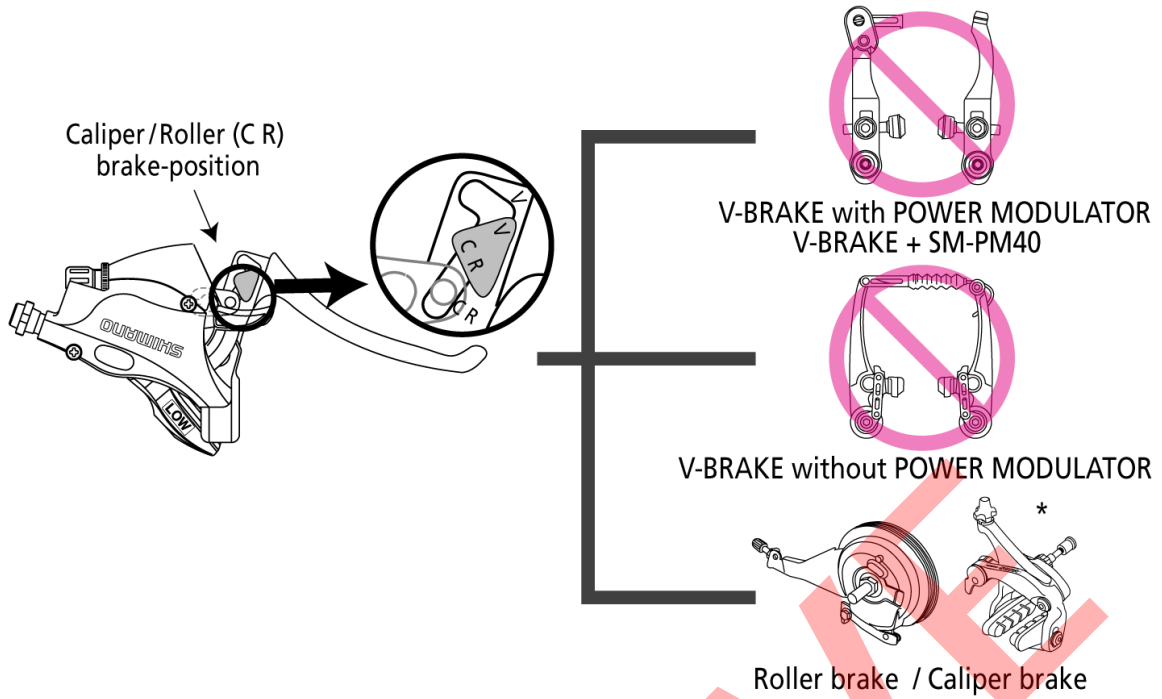

* 3 types of caliper brake is available (SLR-EV / NEW SUPER SLR / SUPER SLR)
Please refer spec hand book for caliper brake compatibility.
Some models can't be used with roller brake, please refer to [C-466](#) for more information.

WARNING

If the mode is not matched to the type of brake being used, this could result in inadequate or excessive braking power. Please proceed with caution when selecting the correct mode for the corresponding brake.

FREEHUB and cassette sprocket spline compatibility

C-731

The table below does not include LINKGLIDE cassette sprockets. See [C-649](#) for LINKGLIDE cassette sprockets.

FREEHUB			Compatible cassette sprocket type					
Free unit type	Number of effective spline teeth	Outer body length (mm)	MTB		ROAD		All	
			12-speed	11-speed	12-speed	11-speed	10/9/8-speed	7-speed
MICRO SPLINE	23	26	✓	-	-	-	-	-
HG spline L2 (ROAD 12-speed dedicated)	18	37.65	-	-	✓	-	-	-
HG spline L (ROAD 12/11-speed)	9	36.75	-	✓ *1	✓	✓ *3	✓ *2	-
HG spline M (10/9/8-speed, MTB 11-speed)	9	34.9	-	✓	-	- *4	✓ *5	-
HG spline S (7-speed)	9	31	-	-	-	-	-	✓

*1 Need 1.85 mm low spacer.

*2 Need 1.85 mm low spacer and 1.0 mm spacer for the cassette sprockets below.

CS-7900 / CS-7800 / CS-6700 / CS-6600 / CS-5700 / CS-5600 (1.0 mm spacer is included)

*3 CS-HG800 / CS-HG700 of ROAD 11-speed are compatible with HG spline L by installing 1.85 mm spacer.

*4 CS-HG800 / CS-HG700 of ROAD 11-speed are compatible with HG spline M.

*5 Need 1.0 mm spacer for the 10-speed road cassette sprockets below.

CS-7900 / CS-7800 / CS-6700 / CS-6600 / CS-5700 / CS-5600

Outer body length

Outer body length is length from the contact surface of the cassette sprocket of the free unit to the tip of the free unit.

MICRO SPLINE

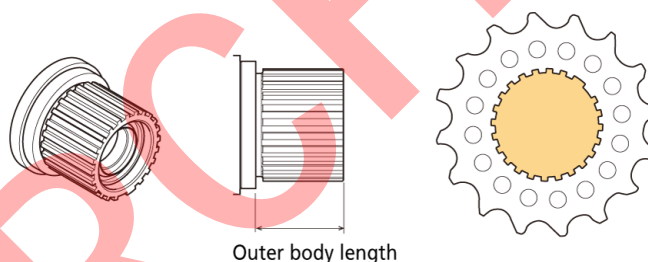

HG spline L2

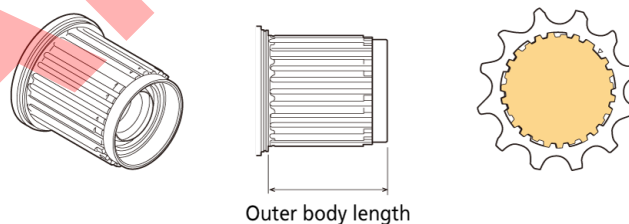

HG spline L/M/S

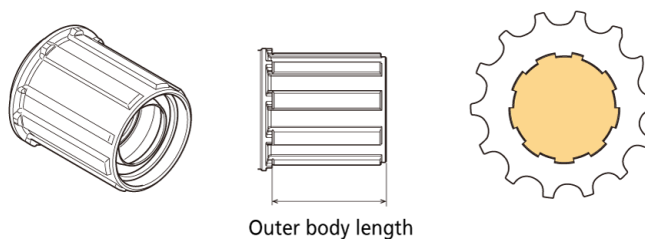

ROAD 12/11-speed FREEHUB compatibility

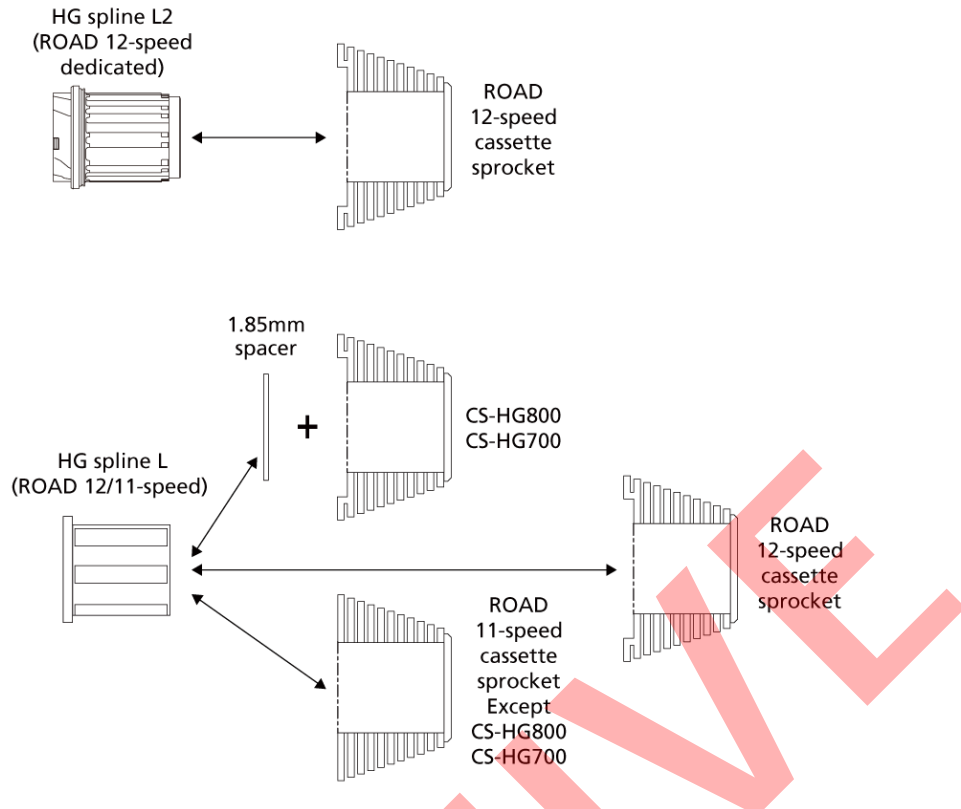

MTB 11-speed FREEHUB compatibility

MTB 11-speed wheel and FREEHUB have same spline shape with 10, 9, 8-speed FREEHUB.

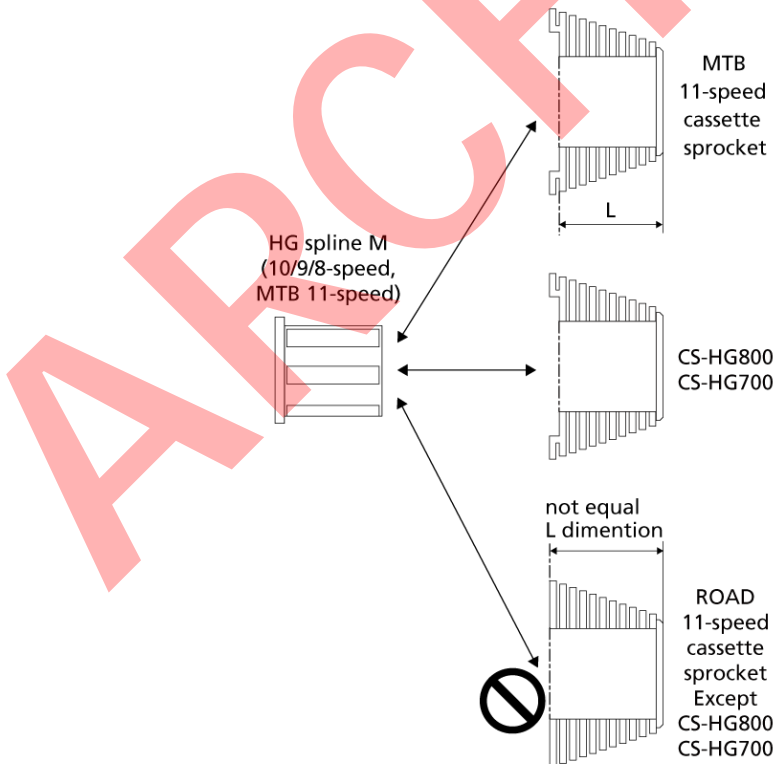

Compatibility between rear derailleur and cassette sprocket gear teeth [ROAD, Gravel, URBAN (METREA)]

C-254

12-speed C-648

Gear	RD-R9250	RD-R8150	RD-R7150
11-30T	✓	✓	-
11-34T	✓	✓	✓
11-36T	-	-	✓

11-speed C-255

Gear	RD-R9100 RD-R9150	RD-R8000 RD-R8050		RD-R7000		RD-9000	RD-6800 RD-6870 RD-5800	
	-	SS	GS Front double	SS	GS Front double	SS	SS	GS Front double
11-23T	-	-	-	-	-	✓	✓	-
11-25T	✓	✓	-	-	-	✓	✓	-
11-28T	✓	✓	✓	✓	✓	✓	✓	✓
11-30T	✓	✓	✓	✓	✓	-	-	✓
11-32T	-	-	✓	-	✓	-	-	✓
11-34T	-	-	✓	-	✓	-	-	✓
11-40T	-	-	-	-	-	-	-	-
11-42T	-	-	-	-	-	-	-	-
12-25T	✓	✓	-	✓	-	✓	✓	-
12-28T	✓	✓	✓	-	✓	✓	✓	✓
14-28T	✓	✓	-	✓	-	✓	✓	-

Gear	RD-RX800 RD-RX805	RD-RX810 RD-RX815	RD-RX812 RD-RX817	RD-U5000-SS
	GS Front double	Closer Front double	Wider Front Single	SS
11-23T	-	-	-	-
11-25T	-	-	-	-
11-28T	✓	-	-	✓
11-30T	✓	✓	-	✓
11-32T	✓	✓	-	✓
11-34T	✓	✓	-	-
11-40T	-	-	✓	-
11-42T	-	-	✓	-
12-25T	-	-	-	-
12-28T	-	-	-	-
14-28T	-	-	-	-

10-speed C-256

Gear	RD-4700			RD-4601			RD-RX400
	SS	GS Front double	GS Front triple	SS	GS Front double	GS Front triple	Closer Front double
11-25T	✓	-	✓	✓	-	✓	-
11-27T	✓	-	✓	✓	✓	✓	-
11-28T	-	✓	✓	✓	✓	✓	-
11-32T	-	✓	✓	-	✓	-	✓
11-34T	-	✓	-	-	-	-	✓
11-36T	-	-	-	-	-	-	✓
12-25T	✓	-	✓	✓	-	✓	-
12-27T	✓	-	✓	✓	✓	✓	-
12-28T	✓	✓	✓	✓	✓	✓	-
12-30T	-	✓	✓	✓	✓	✓	-
13-25T	✓	-	-	✓	-	✓	-
14-25T	✓	-	-	✓	-	✓	-

9-speed C-257

Gear	RD-R3000		
	SS	GS Front double	GS Front Triple
11-25T	✓	-	-
11-28T	✓	✓	✓
11-30T	✓	✓	✓
11-32T	✓	✓	✓
11-34T	-	✓	-
12-25T	✓	-	-
12-27T	✓	-	-
13-25T	✓	-	-
14-25T	✓	-	-

8-speed C-258

Gear	RD-R2000		
	SS	GS Front double	GS Front Triple
11-28T	✓	✓	✓
11-30T	✓	✓	✓
11-32T	✓	✓	✓
11-34T	-	✓	-
12-25T	✓	-	✓
13-26T	✓	-	-

7-speed C-259

Gear	RD-A070
	SMART CAGE
11-28T	✓
12-28T	✓
13-28T	✓
14-28T	✓

LINKGLIDE cassette sprocket and FREEHUB compatibility

C-649

LINKGLIDE cassette sprockets are not compatible with MICRO SPLINE FREEHUB.





Freewheel body type	FREEHUB spec.	Model No.	CS-LG700-11 CS-LG600-11 CS-LG400-11	CS-LG600-10 CS-LG400-10
HG spline M (10/9/8-speed, MTB 11-speed)	O.L.D. 148 mm, E-THRU type	FH-M8010-B	✓	✓
		FH-M6010-B		
		FH-MT400-B		
	O.L.D. 141 mm, Quick release type	FH-MT200-B		
	O.L.D. 150 mm, E-THRU type	FH-M825	✓	✓
	O.L.D. 135 mm, E-THRU type	FH-M820	- *2	✓
	O.L.D. 142 mm, E-THRU type	FH-M8010	- *2	✓
		FH-M6010		
		FH-MT400		
	O.L.D. 135 mm, Quick release type	FH-M9000	- *2	✓
		FH-M8000		
		FH-M6000		
		FH-M4050		
		FH-M3050		
		FH-RM35		
		FH-TX505-8		
		FH-M756-A		
		FH-M525		
		FH-M475		
FH-TX506				
FH-T610				
FH-T3000				
FH-TX500-8-QR				
FH-TX500-8-NT				
O.L.D. 130 mm, Quick release type	FH-R5300	- *2	✓	
HG spline L (ROAD 12/11-speed)	O.L.D. 142 mm, E-THRU type	FH-R7070	✓ *1	✓ *1
		FH-RS770		
		FH-RS470		
	O.L.D. 135 mm, Quick release type	FH-UR600	✓ *1	✓ *1
	O.L.D. 130 mm, Quick release type	FH-R7000	- *2	✓ *1
		FH-RS400		

*1 Need low spacer (1.85 mm.)

*2 Interference may occur with the rear derailleur and spokes.

Available combinations of the dropout, cassette sprocket/single gear and crankset for designing the frame

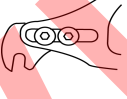
C-471

Dropout design	A	Reversed (BMX) type, without derailleur hanger	
	B	Standard type, without derailleur hanger	
	C	Adjustable disc brake mount / Eccentric bottom bracket	
	D	Vertical type, with derailleur hanger	
Compatibility	NR: Not recommend		-
Crankset	E	FC-C6000	-
	F	FC-S501: Double guard spec	-
	G	FC-S501: Single guard spec	-
	K	SM-CRE61 / SM-CRE50	-
CN	H	CN-NX10 (1/2 x 1/8 inch) or HG 85 (1/2 x 3/32 inch)	-
	I	Super Narrow HG 95	-
	J	HG 85 (1/2 x 3/32 inch)	-

Series	Speed	Brake type	Dropout design	Compatibility	CT use *5	CS / SM-GEAR	FC	CN	additional condition	
ALFINE	11S / 8S	Disc brake	A	NR	-	-	-	-	*1	
			B	NR	-	-	-	-		
			C	OK	-	SM-GEAR	G	J	-	
			D	OK	CT-S500	CS-S500	F	I	-	
		OK		CT-S510	SM-GEAR	G	J	-		
		V-BRAKE	A	OK	-	SM-GEAR	G	J	-	
			B	OK	-	SM-GEAR	G	J	-	
			C	OK	-	SM-GEAR	G	J	-	
D	OK		CT-S500	CS-S500	F	I	-			
	OK	CT-S510	SM-GEAR	G	J	-				
NEXUS	8S / 7S	Disc brake	A	NR	-	-	-	-	*1	
			B	NR	-	-	-	-		
			C	OK	-	SM-GEAR	G	J	-	
			D	OK	CT-S500	CS-S500	F	I	-	
	OK	CT-S510		SM-GEAR	G	J	-			
	8S / 7S / 3S (except 3D)	Hub roller brake V-BRAKE	A	OK	-	SM-GEAR	E	H	-	
			B	OK	-	SM-GEAR	G	J	-	
				OK	-	SM-GEAR	E	H	-	
			D	NR	CT-S500 (except 3s)	CS-S500	F	I	*2	
		OK		CT-S510 (except 3s)	SM-GEAR	G	J	-		
		Coaster brake	A	OK	-	SM-GEAR	E	H	-	
			B	OK	-	SM-GEAR	G	J	-	
				OK	-	SM-GEAR	E	H	-	
			D	NR	-	-	-	-	*3	
		NR		-	-	-	-	*4		
		3D	Disc brake	A	NR	-	-	-	-	*1
				B	NR	-	-	-	-	
	C			OK	-	SM-GEAR	G	J	-	
	D			OK	-	CS-S500	F	I	-	
			OK	-	SM-GEAR	G	J	-		
	V-BRAKE		A	OK	-	SM-GEAR	G	J	-	
			B	OK	-	SM-GEAR	G	J	-	
			C	OK	-	SM-GEAR	G	J	-	
			D	OK	-	CS-S500	F	I	-	
	OK			-	SM-GEAR	G	J	-		
	5S for E-BIKE		Disc brake	A	NR	-	-	-	-	*1
				B	NR	-	-	-	-	
		C		OK	-	CS-C7000	K	J	-	
D		NR		-	-	-	-	-		
Hub roller brake V-BRAKE		A	OK	-	CS-C7000	K	J	-		
		B	OK	-	CS-C7000	K	J	-		
		C	OK	-	CS-C7000	K	J	-		
		D	NR	-	-	-	-	-		
Coaster brake		A	OK	-	CS-C7000	K	J	-		
		B	OK	-	CS-C7000	K	J	-		
		C	OK	-	CS-C7000	K	J	-		
		D	NR	-	-	-	-	-		

*1 Special disc brake mount design is needed.

*2 without chain guard for hub gear side.

*3 Structure of CT-S500 can't transfer chain tension by back pedaling.

*4 Not enough force of fixation against back pedaling power.

*5 Chain tensioners are not compatible with MU-UR510.

Mechanical internal geared hub / SM (CJ) COMPATIBILITY CHART

C-647

Internal Geared Hub (SG)		Spec.	Small Parts Set (SM)	Cassette Joint (CJ) * CJ is included in SM parts set
ALFINE-11	SG-S7001-11	11s, Disc brake, Premium	SM-S700 SM-S700-BD *1	CJ-S700 CJ-S700-BD *1
ALFINE-8	SG-S7001-8	8s, Disc brake, Premium	SM-S7000-8 SM-S7000-8BD *1	CJ-S7000-8 CJ-S7000-8BD *1
INTER-8	SG-C6011-8R	8s, Roller brake, Premium	SM-8S31 SM-8S31BD *1	CJ-8S20 / CJ-8S40 CJ-8S20BD *1
	SG-C6011-8V	8s, V-BRAKE, Premium		
	SG-C6001-8R	8s, Roller brake		
	SG-C6001-8V	8s, V-BRAKE		
	SG-C6001-8C	8s, Coaster brake		
	SG-C6001-8D	8s, Disc brake		
INTER-7	SG-C3001-7R	7s, Roller brake	SM-7R45 SM-7C25 *1	CJ-NX10 / CJ-NX40
	SG-C3001-7V	7s, V-BRAKE	SM-7C25	CJ-NX10 / CJ-NX40
	SG-C3001-7C	7s, Coaster brake	SM-7R45 SM-7C25 *1	CJ-NX10 / CJ-NX40
	SG-C3001-7D	7s, Disc brake		
INTER-5E	SG-C7000-5R	5s, Roller brake, Premium	SM-C7000-5 SM-C7000-5BD *1	CJ-C7000-5 CJ-C7000-5BD *1
	SG-C7000-5V	5s, V-BRAKE, Premium		
	SG-C7000-5C	5s, Coaster brake, Premium		
	SG-C7000-5D	5s, Disc brake, Premium		
	SG-C7002-5CD	5s, Coaster brake & Disc brake		
INTER-5	SG-5R30 (Japan Only)	5s, Roller brake, Japan only	SM-5S30	CJ-8S20 / CJ-8S40
	SG-5R30-VS (Japan Only)	5s, V-BRAKE, Japan only		
	SG-5R35 (Japan Only)	5s, Roller brake, Alloy body, Japan only		
	SG-5R35-VS (Japan Only)	5s, V-BRAKE, Alloy body, Japan only		
INTER-3	SG-3R42 (Japan Only)	3s, Roller brake, Japan only	SM-3R40	-
	SG-3R40 (Japan Only)	-		
	SG-3R40	3s, Roller brake	SM-3R40	SM-BC03 SM-BC06
	SG-3C41	3s, Coaster brake	SM-3R41	-
	SG-3D55	3s, Disc brake	SM-3D55	SM-BC03 SM-BC06
	SG-3R75	3s, Roller brake, Premium	SM-3S70	CJ-NX10 / CJ-NX40

*1 : Dedicated specs for belt drive system

Single gear and chain combination

C-608

Series	Single gear		Chain
	Model No.	Gear thickness (mm)	Model No.
ALFINE	CS-5500	2.0	CN-E6070 CN-HG93 CN-HG53
NEXUS	SM-GEAR (2.3 mm) CS-C7000	2.3	CN-HG71 CN-HG40
	SM-GEAR (3.0 mm)	3.0	CN-NX10

Compatibility for DIN 79010:2020-02

C-672

DIN 79010:2020-02

Fahrräder - Transport- und Lastenfahrrad - Anforderungen und Prüfverfahren für ein- und mehrspurige Fahrräder

(Cycles - Transportation bikes and cargo bikes - Requirements and test methods for single- and multi-track cycles)

Products		Model No.	DIN 79010:2020-02 (Type 1: Single Track) conformance
BRAKE (BR, RT)	Group #1	BR-M9120 / BR-M8120 / BR-M7120 + RT-MT900 / RT-EM910	YES with conditions (*1)
	Group #2	BR-M9120 / BR-M8120 / BR-M7120 + RT-MT800 / RT-EM810	
	Group #3	BR-M9120 / BR-M8120 / BR-M7120 + SM-RT86	
	Group #4	BR-M6120 + SM-RT30 / RT-EM300 / SM-RT66	
	Group #5	BR-MT520 / BR-MT420 + SM-RT30 / RT-EM300 / SM-RT66	
HUB (HB, FH, SG)	FH	FH-M**** / MT*** / TX*** / RS*** / UR*** series	YES (*SHIMANO can't guarantee assembled wheel performance. Please confirm wheel performance by bike manufacturer.)
	SG	SG-C7000-5D / SG-C7050-5D / SG-C6001-8D / SG-C6061-8D SG-C3001-7D	
	HB	HB-M**** / MT*** / TX*** / RS*** series	
	DH	All	
OTHERS	All not mentioned above (DU, CS, CN, RD, FC, etc.)	All	NO YES No special requirement if compare with ISO/EN4210-2 2015

(*1) conditions

Product Spec requirements

Group	Brake pad	RT size	Hose length
			(*Please consider Brake Lever reach adjustment)
Group #1,2,3	Resin pad w/ radiator fin	203 mm (L size)	2200 mm or less (Tire outer diameter = 660 mm or less) 2400 mm or less (Tire outer diameter = 559 mm or less) 2700 mm or less (Tire outer diameter = 406 mm or less)
		180 mm (M size)	1300 mm or less (Tire outer diameter = 660 mm or less) 2000 mm or less (Tire outer diameter = 559 mm or less) 2400 mm or less (Tire outer diameter = 406 mm or less)
Group #4	Resin pad w/o radiator fin	203 mm (L size)	2200 mm or less (Tire outer diameter = 660 mm or less) 2400 mm or less (Tire outer diameter = 559 mm or less) 2700 mm or less (Tire outer diameter = 406 mm or less)
		180 mm (M size)	1300 mm or less (Tire outer diameter = 660 mm or less) 2000 mm or less (Tire outer diameter = 559 mm or less) 2400 mm or less (Tire outer diameter = 406 mm or less)
Group #5	Resin pad w/o radiator fin	203 mm (L size) 180 mm (M size)	3000 mm or less (Tire outer diameter = 660 mm or less)

Limitation & adjustment

Group	RT size	DIN 79010:2020-02 5.5.2.2.2 Weight factor "c" (*2)	Brake lever adjustment
Group #1	203 mm (L size)	c = 1.5	Brake lever reach adjustment might be required to follow minimum braking force value of 5.5.1.3
	180 mm (M size)	c = 1.4	
Group #2	203 mm (L size)	c = 1.4	
	180 mm (M size)	c = 1.3	
Group #3	203 mm (L size)	c = 1.3	
	180 mm (M size)	c = 1.1	
Group #4,5	203 mm (L size)	c = 1.1	
	180 mm (M size)	c = 0.9	

(*2) Refer to DIN 79010:2020-02 5.5.2.2.2 about "c" value.

c: weight factor which is defined by bike design. $c = (AL: \text{axle load}) / (M: 100 \text{ kgf as basic value})$.
For example, axle load is allowed till 150 kgf if $c = 1.5$.

Spoke protector

C-491

Select the spoke protector after checking the chart below.
It is decided by hole number of hub and number of the gear teeth, other than multiple freewheel.

Cassette sprocket		Spoke protector model																	
		Flange diameter of rear hub (FH side)																	
		53.8 mm							70.6 mm										
Speed	Model No.	Number of largest sprocket teeth											Spoke hole number						
		25T	28T	30T	32T	34T	36T	40T	42T	45T	46T	51T	28H			32H			36H
12-speed	CS-M9101	-	-	-	-	-	-	-	-	✓	-	✓	-	-	-	-	-	-	-
	CS-M9100	-	-	-	-	-	-	-	-	✓	-	✓	-	-	-	-	-	-	-
	CS-M8100	-	-	-	-	-	-	-	-	✓	-	✓	-	-	-	-	-	-	-
	CS-M7100	-	-	-	-	-	-	-	-	✓	-	✓	-	-	-	-	-	-	-
	CS-M6100	-	-	-	-	-	-	-	-	-	-	✓	-	-	-	-	-	-	-
11-speed	CS-M9001	-	-	-	-	-	-	✓	-	-	-	-	-	-	-	-	-	-	-
	CS-M8000	-	-	-	-	-	-	✓	✓	-	✓	-	-	-	-	-	-	-	-
	CS-M7000	-	-	-	-	-	-	✓	✓	-	✓	-	-	-	-	-	-	-	-
	CS-M5100	-	-	-	-	-	-	✓	-	-	✓	-	-	-	-	-	-	-	-
10-speed	CS-M4100	-	-	-	-	-	-	✓	-	✓	-	-	-	-	-	-	-	-	-
	CS-M771-10	-	-	-	✓	✓	✓	-	-	-	-	-	-	CP-FH56	CP-FH53	-	CP-FH76	CP-FH76	
	CS-HG81-10	-	-	-	-	✓	✓	-	-	-	-	-	-	CP-FH56	CP-FH53	-	CP-FH76	CP-FH76	
	CS-HG500-10	✓	✓	-	✓	✓	-	-	✓	-	-	-	-	-	-	-	-	-	
9-speed	CS-HG50-10	-	-	-	-	-	✓	-	-	-	-	-	-	CP-FH56	CP-FH53	-	-	-	
	CS-HG400-9	-	-	-	-	-	✓	-	-	-	-	-	-	CP-FH56	CP-FH53	-	CP-FH76	CP-FH76	
	CS-HG300-9	-	-	-	-	-	✓	-	-	-	-	-	-	CP-FH56	CP-FH53	-	CP-FH76	CP-FH76	
	CS-HG201-9	-	-	-	-	-	✓	-	-	-	-	-	-	CP-FH56	CP-FH53	-	CP-FH76	CP-FH76	
	CS-HG200-9	-	-	-	-	-	✓	-	-	-	-	-	-	CP-FH56	CP-FH53	-	CP-FH76	CP-FH76	
	CS-HG400-9	-	-	-	✓	✓	-	-	-	-	-	-	CP-WH12	CP-FH56	CP-FH53	-	CP-FH76	CP-FH76	
	CS-HG201-9	-	-	-	✓	✓	-	-	-	-	-	-	CP-WH12	CP-FH56	CP-FH53	-	CP-FH76	CP-FH76	
CS-HG200-9	-	-	-	✓	✓	-	-	-	-	-	-	CP-WH12	CP-FH56	CP-FH53	-	CP-FH76	CP-FH76		
8-speed	CS-HG400-9	-	✓	-	-	-	-	-	-	-	-	-	-	CP-FH35	CP-FH50	-	CP-FH76	CP-FH76	
	CS-HG300-9	-	✓	-	-	-	-	-	-	-	-	-	-	CP-FH35	CP-FH50	-	CP-FH76	CP-FH76	
	CS-ROAD	-	✓	-	-	-	-	-	-	-	-	-	CP-FH08	CP-FH35	CP-FH31	-	-	-	
	CS-HG60-81	-	-	-	-	✓	-	-	-	-	-	-	CP-WH12	CP-FH56	CP-FH53	-	CP-FH76	CP-FH76	
	CS-HG51-8	-	✓	✓	-	-	-	-	-	-	-	-	CP-FH40	CP-FH35	CP-FH50	-	-	-	
	CS-HG51-8	-	-	-	-	✓	-	-	-	-	-	-	CP-WH12	CP-FH56	CP-FH53	-	CP-FH76	CP-FH76	
	CS-HG41-8	-	-	✓	-	-	-	-	-	-	-	-	CP-FH40	CP-FH35	CP-FH50	-	-	-	
CS-HG31-8	-	-	✓	-	-	-	-	-	-	-	-	CP-FH40	CP-FH35	CP-FH50	-	-	-		
7-speed	CS-HG41-8	-	-	-	✓	✓	-	-	-	-	-	-	CP-WH12	CP-FH56	CP-FH53	-	CP-FH76	CP-FH76	
	CS-HG31-8	-	-	-	✓	✓	-	-	-	-	-	-	CP-WH12	CP-FH56	CP-FH53	-	CP-FH76	CP-FH76	
	CS-HG200-8	-	-	-	✓	-	-	-	-	-	-	-	CP-WH12	CP-FH56	CP-FH53	-	CP-FH76	CP-FH76	
	CS-HG41-7	-	✓	-	-	-	-	-	-	-	-	-	CP-FH40	CP-FH35	CP-FH50	-	-	-	
	CS-HG200-7	-	✓	-	✓	-	-	-	-	-	-	-	-	CP-FH56	CP-FH53	-	CP-FH76	CP-FH76	
7-speed	CS-HG200-7	-	✓	-	-	-	-	-	-	-	-	-	-	CP-FH35	CP-FH50	-	-	-	

12-speed

Model No.	Cassette sprocket		Spoke protector model					WH-M9000 WH-M9020 WH-M8000 WH-M8020 WH-M8000-B WH-M8020-B
	Number of largest sprocket teeth		WH-M8100	WH-M8120	WH-MT620	WH-MT601	WH-MT501	
	45T	51T						
CS-M9101	✓	✓						-
CS-M9100	✓	✓	CP-WH28	CP-WH32 (for 10-45T) CP-WH29 (for 10-51T)	CP-WH31 (for 10-45T) CP-WH27 (for 10-51T)	CP-WH31 (for 10-45T) CP-WH27 (for 10-51T)	CP-WH31 (for 10-45T) CP-WH27 (for 10-51T)	-
CS-M8100	✓	✓						-
CS-M7100	✓	✓						-
CS-M6100	-	✓	-	-	-	-	-	-

Model No.	Cassette sprocket		Spoke protector model			
	Number of largest sprocket teeth		WH-MT600	WH-MT500	WH-MT66-29	WH-MT35 WH-MT35-275 WH-MT35-29 WH-MT15-A-275 WH-MT15-A-29
	45T	51T				
CS-M9101	✓	✓	-	-	-	-
CS-M9100	✓	✓	-	-	-	-
CS-M8100	✓	✓	-	-	-	-
CS-M7100	✓	✓	-	-	-	-
CS-M6100	-	✓	-	-	-	-

11-speed

Model No.	Cassette sprocket					Spoke protector model					WH-M9000 WH-M9020 WH-M8000 WH-M8020 WH-M8000-B WH-M8020-B
	Number of largest sprocket teeth					WH-M8100	WH-M8120	WH-MT620	WH-MT601	WH-MT501	
	40T	42T	46T	50T	51T						
CS-M9001	✓	-	-	-	-	-	-	-	-	-	CP-WH17-A
CS-M8000	✓	✓	✓	-	-	-	-	-	-	-	CP-WH17-A
CS-M7000	✓	✓	✓	-	-	-	-	-	-	-	CP-WH17-A
CS-M5100	-	✓	-	-	✓	-	-	-	-	-	CP-WH17-A (for 42T)
CS-LG700-11	-	-	-	✓	-	-	-	-	-	-	-
CS-LG600-11	-	-	-	✓	-	-	-	-	-	-	-
CS-LG400-11	-	-	-	✓	-	-	-	-	-	-	-

Model No.	Cassette sprocket					Spoke protector model				WH-MT35 WH-MT35-275 WH-MT35-29 WH-MT15-A-275 WH-MT15-A-29
	Number of largest sprocket teeth					WH-MT600	WH-MT500	WH-MT66-29		
	40T	42T	46T	50T	51T					
CS-M9001	✓	-	-	-	-	CP-WH26	-	-	-	
CS-M8000	✓	✓	✓	-	-	CP-WH26	-	-	-	
CS-M7000	✓	✓	✓	-	-	CP-WH26	-	-	-	
CS-M5100	-	✓	-	-	✓	CP-WH26 (for 42T)	-	-	-	
CS-LG700-11	-	-	-	✓	-	-	-	-	-	
CS-LG600-11	-	-	-	✓	-	-	-	-	-	
CS-LG400-11	-	-	-	✓	-	-	-	-	-	

10-speed

Model No.	Cassette sprocket						Spoke protector model					
	Number of largest sprocket teeth						WH-M8100	WH-M8120	WH-MT620	WH-MT601	WH-MT501	WH-M9000 WH-M9020 WH-M8000 WH-M8020 WH-M8000-B WH-M8020-B
32T	34T	36T	42T	43T	46T							
CS-M4100	-	-	-	✓	-	✓	-	-	-	-	-	-
CS-M771-10	✓	✓	✓	-	-	-	-	-	-	-	-	-
CS-HG81-10	-	✓	✓	-	-	-	-	-	-	-	-	-
CS-HG500-10	-	-	-	✓	-	-	-	-	-	-	-	-
CS-HG50-10	-	-	✓	-	-	-	-	-	-	-	-	-
CS-LG600-10	-	-	-	-	✓	-	-	-	-	-	-	-
CS-LG400-10	-	-	-	-	✓	-	-	-	-	-	-	-

Model No.	Cassette sprocket						Spoke protector model			
	Number of largest sprocket teeth						WH-MT600	WH-MT500	WH-MT66-29	WH-MT35 WH-MT35-275 WH-MT35-29 WH-MT15-A-275 WH-M815-A-29
32T	34T	36T	42T	43T	46T					
CS-M4100	-	-	-	✓	-	✓	-	-	-	-
CS-M771-10	✓	✓	✓	-	-	-	CP-WH16	CP-WH21	CP-WH16	CP-WH12
CS-HG81-10	-	✓	✓	-	-	-	CP-WH16	CP-WH21	CP-WH16	CP-WH12
CS-HG500-10	-	-	-	✓	-	-	-	CP-WH21	-	CP-WH19
CS-HG50-10	-	-	✓	-	-	-	CP-WH16	CP-WH21	CP-WH16	CP-WH12
CS-LG600-10	-	-	-	-	✓	-	CP-WH26	CP-WH21	-	-
CS-LG400-10	-	-	-	-	✓	-	-	-	-	-

9-speed

Model No.	Cassette sprocket				Spoke protector model					
	Number of largest sprocket teeth				WH-M8100	WH-M8120	WH-MT620	WH-MT601	WH-MT501	WH-M9000 WH-M9020 WH-M8000 WH-M8020 WH-M8000-B WH-M8020-B
28T	32T	34T	36T							
CS-HG400-9 CS-HG300-9 CS-HG201-9 CS-HG200-9	-	✓	✓	✓	-	-	-	-	-	-
CS-HG400-9 CS-HG300-9	✓	-	-	-	-	-	-	-	-	-

Model No.	Cassette sprocket				Spoke protector model			
	Number of largest sprocket teeth				WH-MT600	WH-MT500	WH-MT66-29	WH-MT35 WH-MT35-275 WH-MT35-29 WH-MT15-A-275 WH-MT15-A-29
28T	32T	34T	36T					
CS-HG400-9 CS-HG300-9 CS-HG201-9 CS-HG200-9	-	✓	✓	✓	-	-	CP-WH16	CP-WH12
CS-HG400-9 CS-HG300-9	✓	-	-	-	-	-	CP-WH16	CP-WH08

Model No.	Total number of cassette sprockets				Number of largest sprocket teeth									
	9-speed	10-speed	11-speed**	12-speed	23T	25T	27T	28T	30T	32T*	34T	36T	40T	42T
WH-R9270-C60	-	-	-	✓	-	-	-	-	CP-WR92C			-	-	-
WH-R9270-C50 WH-R9270-C36	-	-	-	✓	-	-	-	-	CP-WR92A			-	-	-
WH-R9200-C60 WH-R9200-C50 WH-R9200-C36	-	-	-	✓	-	-	-	-	CP-W124			-	-	-
WH-R8170-C60 WH-R8170-C50 WH-R8170-C36	-	-	✓	✓	-	-	-	CP-WR81A			-	-	-	
WH-RS710-C32 WH-RS710-C46	-	-	✓	✓	-	-	-	CP-WH24			CP-WR71A	-	-	
WH-R9170-C60 WH-R9170-C40	-	✓	✓	-	-	CP-W1460			-	-	-	-	-	
WH-R9100-C60 WH-R9100-C40	-	✓	✓	-	-	CP-W124			-	-	-	-	-	
WH-R9100-C24	-	✓	✓	-	CP-WH23	CP-W120			-	-	-	-	-	
WH-RS770-C30	-	-	✓	-	CP-W020			-	-	-	-	-	-	
	-	✓	-	-	CP-W1460			-	CP-W1460	-	-	-	-	
WH-RS700-C30	-	-	✓	-	-	CP-W124			-	CP-W124	-	-	-	
	-	✓	-	-	-	CP-W124			-	-	-	-	-	
WH-RS500 WH-RS300 WH-RS11	-	-	✓	-	CP-WH23			-	CP-W120	-	-	-	-	
WH-RS11	-	✓	-	-	CP-W020			-	-	-	-	-	-	
WH-9000-C24-TU WH-RS330-CL	-	-	✓	-	CP-W184			-	CP-W124	-	-	-	-	
	-	✓	-	-	CP-W024			-	-	-	-	-	-	
WH-RX830	-	✓	✓	-	-	CP-W1220			-	CP-WH14 CP-WH14A	-	-	-	
WH-RX31	-	✓	✓	-	-	CP-W122			-	-	-	-	-	
WH-RS100	-	✓	✓	-	-	CP-WH24			-	CP-FH53	-	-	-	
WH-RS010-CL	-	✓	✓	-	-	CP-WH24			-	CP-FH53	-	-	-	
WH-R501 WH-R501-A	✓	✓	-	-	CP-FH06	CP-FH31	CP-FH46	CP-WH24	-	-	-	-	-	
	-	-	✓	-	CP-FH08	-	-	CP-WH12	-	-	-	-	-	
WH-RS170	-	✓	-	-	CP-FH40 CP-FH41	CP-FH40 CP-FH41	CP-WH12	CP-WH12	CP-WH12	-	-	-	-	
	-	-	✓	-	CP-FH08	-	CP-WH12	-	-	-	-	-	-	
WH-RS171	-	✓	-	-	CP-FH40 CP-FH41	CP-FH40 CP-FH41	CP-WH12	CP-WH12	CP-WH12	-	-	-	-	
	-	-	✓	-	CP-FH08	-	CP-WH12	-	-	-	-	-	-	
WH-RX010-CL	-	✓	-	-	CP-FH40 CP-FH41	CP-FH40 CP-FH41	CP-WH12	CP-WH12	CP-WH12	-	-	-	-	
	✓	✓	-	-	CP-FH08	CP-FH40 CP-FH41	CP-WH12	-	-	-	-	-	-	
WH-U5000	-	✓	✓	-	-	CP-W122			-	-	-	-		
WH-RS370	-	✓	✓	-	-	CP-WH12			-	-	-	-		
	-	✓	-	-	CP-WH41			CP-WH12	-	-	-	-		
WH-RX870	-	-	✓	✓	-	-	-	-	-	CP-WH30	-	CP-WH26		
WH-RX570	-	✓	✓	-	-	CP-WH30			CP-WH41	CP-WH12	-	-		

* For compact crank set

** 11-speed : CS-R9100 / CS-R8000 / CS-R7000 / CS-6800 / CS-5800

Spoke protector for Road

Speed	Model No.	Number of largest sprocket teeth										Spoke holes No.			
		21T	23T	24T	25T	26T	27T	28T	30T	32T	34T	24H	28H	32H	36H
8, 9, 10-speed	Road	✓	✓	-	✓	-	-	-	-	-	-	CP-FH06	CP-FH08	CP-FH05	CP-FH06
		-	-	-	-	✓	-	-	-	-	-	CP-FH31	CP-FH08	CP-FH35	CP-FH31
		-	-	-	-	-	✓	✓	-	-	-	CP-FH31	CP-FH08	CP-FH35	CP-FH31
		-	-	-	-	-	-	-	✓	-	-	-	-	CP-FH45	CP-FH46
7-speed	CS-HG200-7	-	-	-	-	-	-	✓	-	-	-	-	-	CP-FH35	CP-FH50
	MF-TZ500-7	-	-	-	-	-	-	✓	-	-	-	-	-	-	CP-HG22/ MF-TZ500-7-CP/ MF-TZ21-CP
	MF-TZ21	-	-	-	-	-	-	✓	-	-	-	-	-	-	

Spoke protector is not available for Road 11-speed FREEHUB.

E-BIKE system compatibility chart

C-525

Compatibility chart of E-TUBE PROJECT Cyclist/Professional v5.1.2

SHIMANO STEPS with Gen.2 Battery Management System

This is a compatibility table when using the following batteries.

- SHIMANO STEPS Gen.2 battery
- Battery with hardware and firmware compatible with Gen.2 made by partner manufacturers.

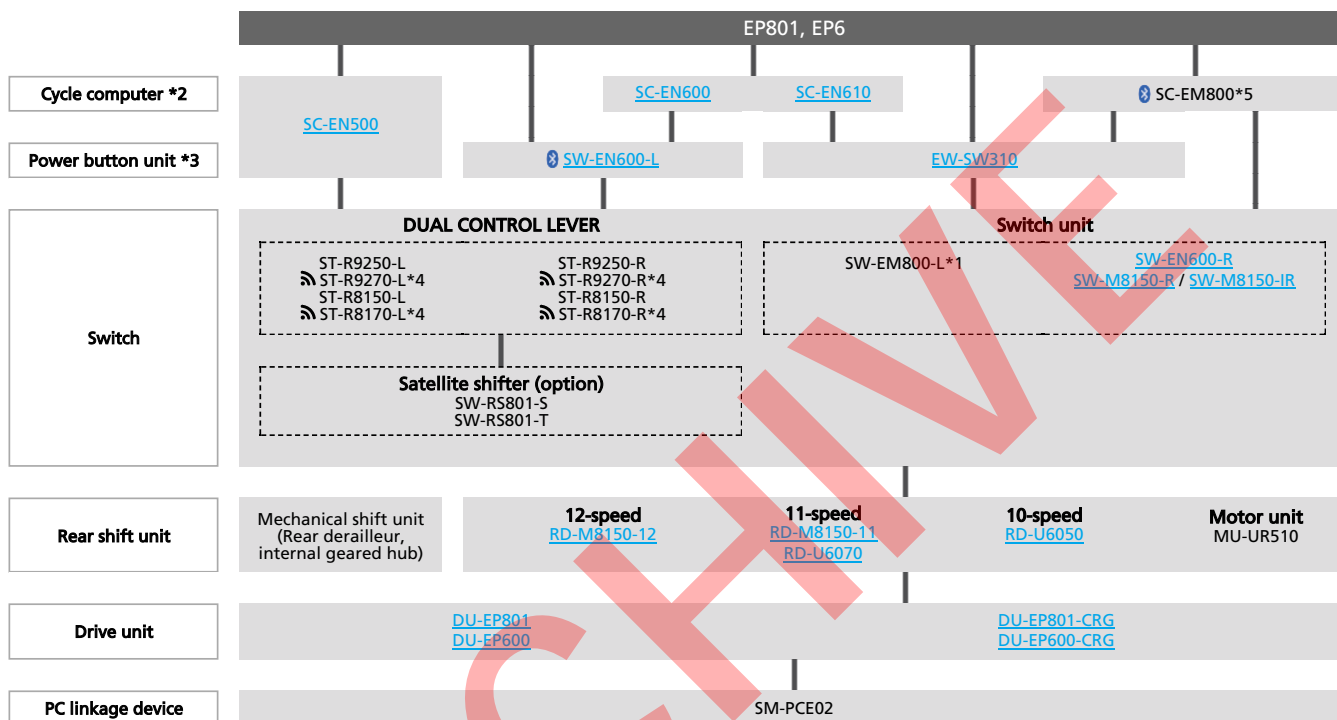

Limitation of function

- *1 Need to change Switch setting by E-TUBE PROJECT to use as shift switch
- *2 When system has power button unit, cycle computer isn't mandatory
- *3 When system has cycle computer, assist up/down and power on/off function on other unit, power button unit isn't mandatory
- *4 Wired connection only
- *5 When drive unit (US class 3) is connected, cycle computer can displays main screen (speed and assist bar) only
- *6 When system has 3rd party CAN cycle computer, SHIMANO cycle computer and power button unit isn't mandatory

SHIMANO STEPS with 1st generation Battery Management System (for 3rd party battery *)

* This is a compatibility table when using a battery made by a partner manufacturer that ensures compatibility only by updating the firmware.

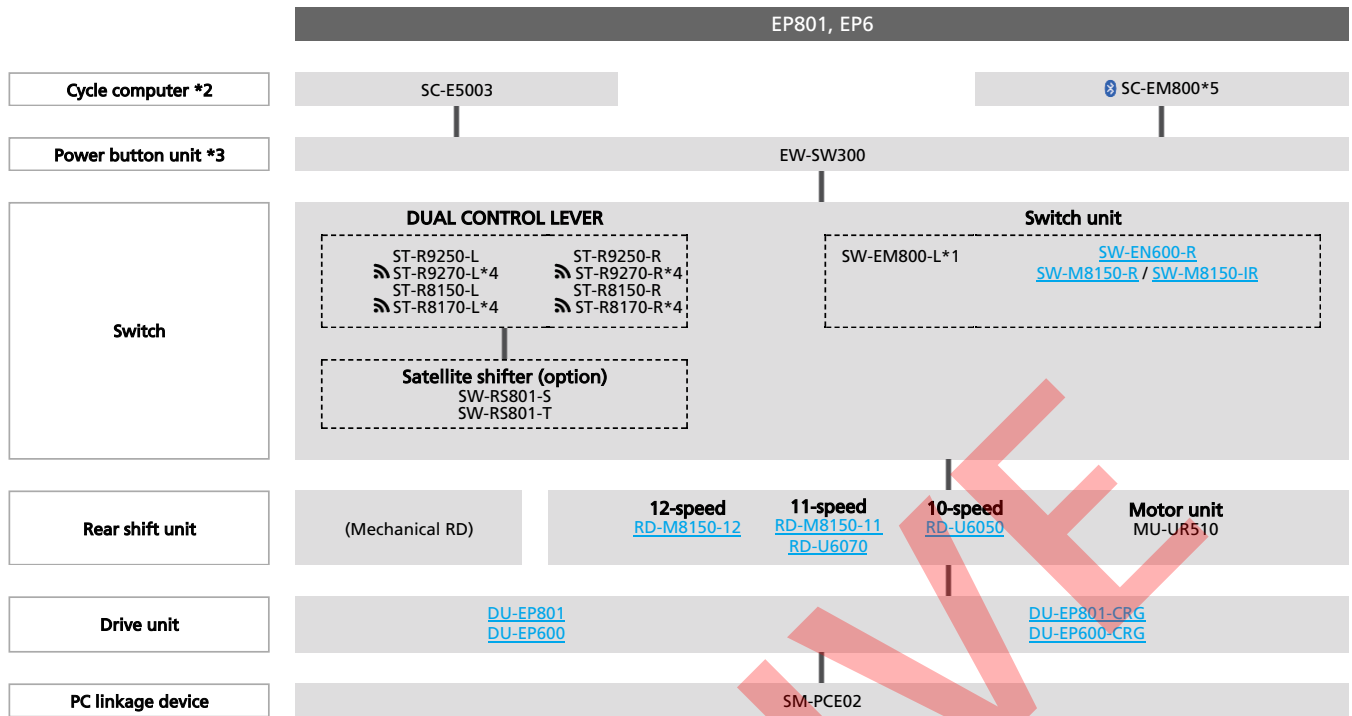

Limitation of function

- *1 Need to change Switch setting by E-TUBE PROJECT to use as shift switch
- *2 Cycle computer is mandatory
- *3 When power on/off function on other unit, power button unit isn't mandatory
- *4 Wired connection only
- *5 When drive unit (US class 3) is connected, cycle computer can displays main screen (speed and assist bar) only

NOTE

Gen.2 battery management system is not compatible with a battery with hardware and firmware compatible with conventional system made by partner manufacturers

SHIMANO STEPS with 1st generation Battery Management System (SHIMANO 1st generation battery and compatible 3rd party battery *)

* This is a compatibility table when using the following batteries.

- SHIMANO STEPS 1st generation battery
- Battery with hardware and firmware compatible with conventional system made by partner manufacturers.

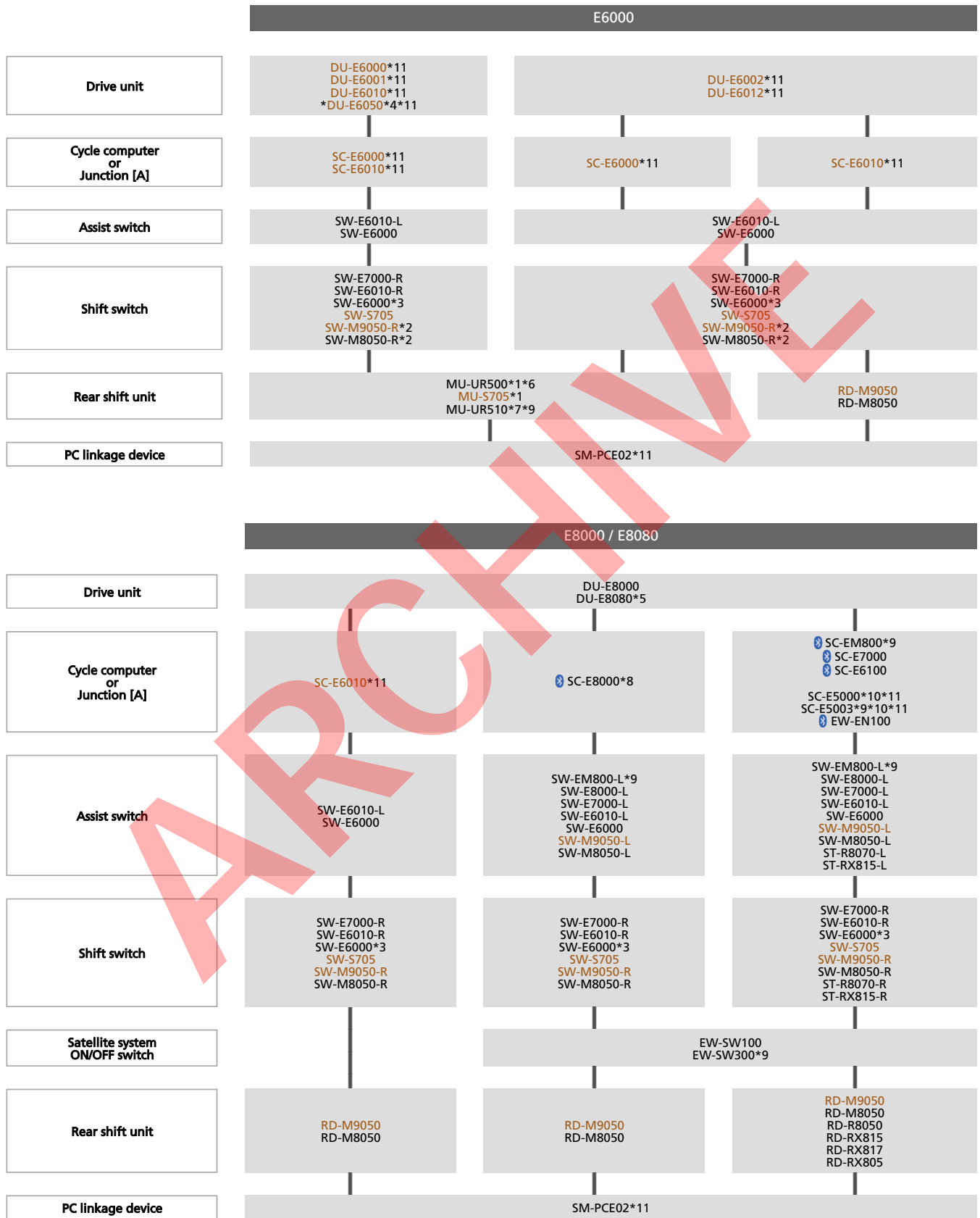

	E7000	EP800 / E6100 / E6180 / E5000 / E5080
Drive unit	DU-E7000	DU-EP800*9 DU-EP800-CRG*9 DU-E6100 DU-E6100-CRG DU-E6110 DU-E6180*5 DU-E5000 DU-E5080*5 DU-E5080-H*5
Cycle computer or Junction [A]	EW-SD300 compatible SC-EM800*9 SC-E5003*9*10*11	EW-SD50 compatible SC-E7000 SC-E6100 SC-E5000*10*11 EW-EN100
Switch unit	SW-EM800-L*9*12 SW-E8000-L SW-E7000-L SW-E6010-L SW-M9050-L SW-M8050-L ST-R8070-L ST-RX815-L	SW-E7000-R SW-E6010-R SW-S705 SW-M9050-R SW-M8050-R ST-R8070-R ST-RX815-R
Satellite system ON/OFF switch	EW-SW300*9	EW-SW100
Rear shift unit	RD-M9050 RD-M8050 RD-R8050 RD-RX815 RD-RX817 RD-RX805	MU-UR510*7*9 MU-UR500*7 MU-S705*7 RD-M9050 RD-M8050 RD-R8050 RD-RX815 RD-RX817 RD-RX805
PC linkage device		SM-PCE02*11

Limitation of function

- *1 Full automatic shift is available only with 8-speed internal geared hub system (Not available with Rear Derailleur)
- *2 Not support full automatic shift
- *3 Need to change Switch setting by E-TUBE PROJECT
- *4 North American market only
- *5 Japanese market only
- *6 Compatible with 11-speed and 8-speed internal geared hub system only
- *7 Full automatic shift is available only with 8 speed and 5 speed internal geared hub system (Not available with Rear Derailleur)
- *8 Not available in Japan market
- *9 This unit has SD300 port, and needs EW-AD305 for connection with SD50 port unit
- *10 Only for ø22.2 handlebar. Drop handlebar is unavailable
- *11 Not supported by E-TUBE PROJECT Cyclist
- *12 Need to change switch setting by E-TUBE PROJECT to use as shift switch

EP8 series ([DU-EP801](#)) / EP6 series C-706

12-speed Rear derailleur spec.

Shifting system	Chain type	Rear sprocket	Crank arm	Front shifting system	Chainring	Chain line (mm)	Chain guard	Chain device	Maximum torque from drive unit (Nm)
HYPERGLIDE+ 12-speed (Di2, Mechanical)	HG 12-speed	HYPERGLIDE+ 12-speed	FC-EM900 FC-M8150 FC-EM600	Single	CR-EM800 32T	55	-	CD-EM800 w/o plate	* 85
					SM-CRE80-12-SB 34T/36T	56.5	-	CD-EM800	85
					SM-CRE80-12-B 34T/36T/38T	55	-	CD-EM800 (Chain line: 55 mm)	
					SM-CRE70-12-B 36T	55	-	CD-EM800 (Chain line: 55 mm)	
					SM-CRE80-12-B 34T/36T/38T	53	-	CD-EM800 SM-CDE80 SM-CDE70	
					SM-CRE70-12-B 36T	53	-	CD-EM800 SM-CDE80 SM-CDE70	
					SM-CRE80-R 47T	50	Double	-	
					SM-CRE70-12 42T	50	Double	-	

* Perfect shifting performance by high torque is not required.

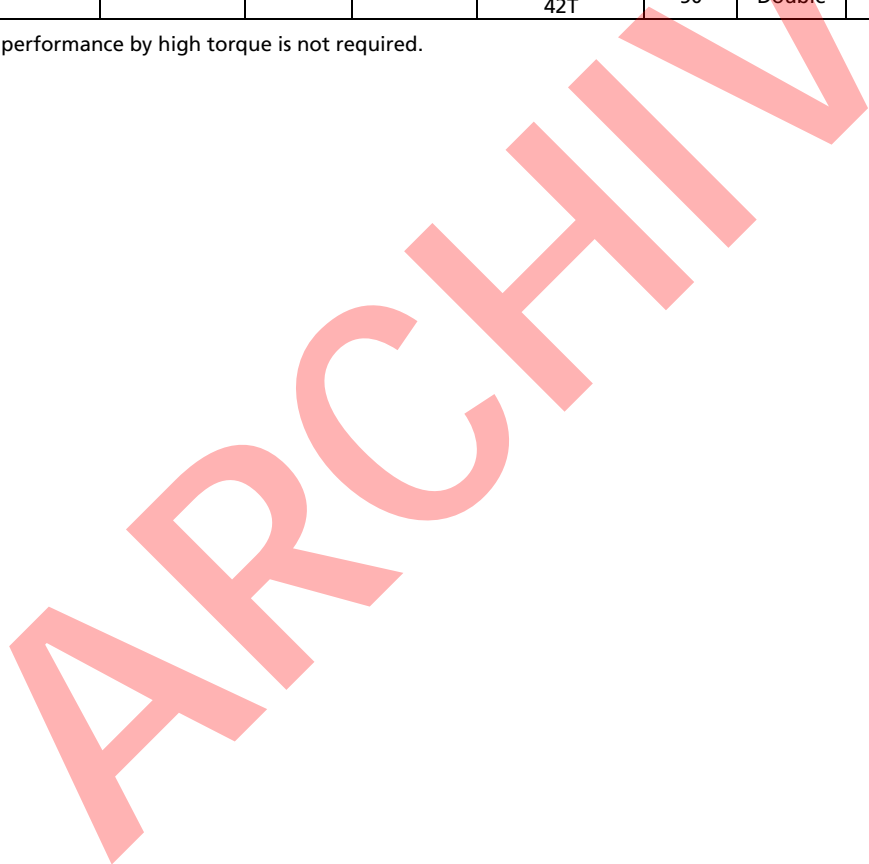

11/10/9-speed Rear derailleur spec.

Shifting system	Chain type	Rear sprocket	Crank arm	Front shifting system	Chainring	Chain line (mm)	Chain guard	Chain device	Maximum torque from drive unit (Nm)
LINKGLIDE (Di2, Mechanical)	LINKGLIDE HG 11-speed	LINKGLIDE	FC-EM900 FC-M8150 FC-EM600	Single	SM-CRE80-B 34T/38T	55	-	CD-EM800 (Chain line: 55 mm)	85
					SM-CRE70-B 34T	55	-	CD-EM800 (Chain line: 55 mm)	
					SM-CRE80 34T/38T	50	-	CD-EM800 SM-CDE80 SM-CDE70	85
					SM-CRE70-B 34T	53	-	CD-EM800 SM-CDE80 SM-CDE70	
					SM-CRE80-B 34T/38T	53	-	CD-EM800 SM-CDE80 SM-CDE70	
					SM-CRE80 44T	50	Double	-	
					SM-CRE80-R 47T	50	-	-	
					SM-CRE70 38T	50	-	SM-CDE80 w/o plate	
					SM-CRE70 38T	50	Double	-	85
					CR-ET600 38T/44T	50	Double	-	
HG 11-speed (Di2, Mechanical)	LINKGLIDE HG 11-speed	HG 11-speed	FC-EM900 FC-M8150 FC-EM600	Single	SM-CRE80-B 34T/38T	53	-	CD-EM800 SM-CDE80 SM-CDE70	85
					SM-CRE70-B 34T	53	-	CD-EM800 SM-CDE80 SM-CDE70	
					SM-CRE80 34T/38T	50	-	SM-CDE80 w/o plate	
					SM-CRE80 44T	50	Double	-	
					SM-CRE80-R 47T	50	Double	-	
					SM-CRE70 38T	50	-	SM-CDE80 w/o plate	
HG 10-speed (Mechanical)	HG-X 10-speed HG 10-speed	HG 10-speed			SM-CRE70 38T	50	Double	-	85
					CR-ET600 38T/44T	50	Double	-	
HG 9-speed (Mechanical)	HG 9-speed	HG 9-speed	FC-EM900 FC-M8150 FC-EM600	Single	SM-CRE70-B 34T	55	-	CD-EM800 (Chain line: 55mm)	85
					SM-CRE70-B 34T	53	-	CD-EM800 SM-CDE80 SM-CDE70	85
					SM-CRE80-R 47T	50	Double	-	
					SM-CRE70 38T	50	-	SM-CDE80 w/o plate	
					SM-CRE70 38T	50	Double	-	85
CR-ET600 38T/44T	50	Double	-						

Internal geared hub spec.

Shifting system	Chain type	Rear sprocket	Crank arm	Front shifting system	Chainring	Chain line (mm)	Chain guard	Chain device	Maximum torque from drive unit (Nm)
ALFINE INTER-11/8 (Di2, Mechanical)	HG 9-speed	CS-S500		Single	SM-CRE61 38T/44T	46.5	Single, w/o	-	50
					CR-ET600 38T/44T	50	Double, Single, w/o	-	
NEXUS INTER-8 (Di2, Mechanical)	HG Single speed 1/2 inch x 1/8 inch	SM-GEAR	FC-EM900 FC-M8150 FC-EM600	Single	SM-CRE61 38T/44T	46.5	Single, w/o	-	85
					CR-ET600 38T/44T	50	Double, Single, w/o	-	
NEXUS INTER-5E (Di2, Mechanical)	HG	CS-C7000		Single	SM-CRE61 38T/44T	46.5	Single, w/o	-	85
					CR-ET600 38T/44T	50	Double, Single, w/o	-	

12-speed Rear derailleur spec.

Shifting system	Chain type	Rear sprocket	Crank arm	Front shifting system	Chainring	Chain line (mm)	Chain guard	Chain device	Maximum torque from drive unit (Nm)
HYPERGLIDE+ 12-speed (Di2, Mechanical)	HG 12-speed	HYPERGLIDE+ 12-speed	FC-EM900 FC-M8150 FC-EM600	Single	CR-EM800 32T	55	-	CD-EM800 w/o plate	* 85
					SM-CRE80-12-SB 34T/36T	56.5	-	CD-EM800	85
					SM-CRE80-12-B 34T/36T/38T	55	-	CD-EM800 (Chain line: 55mm)	
					SM-CRE70-12-B 36T	55	-	CD-EM800 (Chain line: 55mm)	
					SM-CRE80-12-B 34T/36T/38T	53	-	CD-EM800 SM-CDE80 SM-CDE70	
					SM-CRE70-12-B 36T	53	-	CD-EM800 SM-CDE80 SM-CDE70	
					SM-CRE80-R 47T	50	-	-	
					SM-CRE70-12 42T	50	Double	-	

* Perfect shifting performance by high torque is not required.

11/10-speed Rear derailleur spec.

Shifting system	Chain type	Rear sprocket	Crank arm	Front shifting system	Chainring	Chain line (mm)	Chain guard	Chain device	Maximum torque from drive unit (Nm)		
LINKGLIDE (Di2, Mechanical)	LINKGLIDE HG 11-speed	LINKGLIDE	FC-EM900 FC-M8150 FC-EM600	Single	SM-CRE80-B 34T/38T	55	-	CD-EM800 (Chain line: 55 mm)	85		
					SM-CRE70-B 34T	55	-	CD-EM800 (Chain line: 55 mm)			
					SM-CRE80-B 34T/38T	53	-	CD-EM800 SM-CDE80 SM-CDE70	85		
					SM-CRE80-R 47T	50	-	-			
SM-CRE80 34T/38T	50	-			SM-CDE80 w/o plate						
SM-CRE80 44T	50	Double			-						
HG 11-speed (Di2, Mechanical)	LINKGLIDE HG 11-speed	HG 11-speed			FC-EM900 FC-M8150 FC-EM600	Single	SM-CRE70-B 34T	53	-	CD-EM800 SM-CDE80 SM-CDE70	85
							SM-CRE70 38T	50	-	SM-CDE80 w/o plate	
			SM-CRE70 38T	50			Double	-			
HG 10-speed (Mechanical)	HG-X 10-speed HG 10-speed	HG 10-speed	FC-EM900 FC-M8150 FC-EM600	Single			CR-ET600 38T/44T	50	Double	-	85
							SM-CRE70 38T	50	Double	-	

Internal geared hub spec.

Shifting system	Chain type	Rear sprocket	Crank arm	Front shifting system	Chainring	Chain line (mm)	Chain guard	Chain device	Maximum torque from drive unit (Nm)
ALFINE INTER-11/8 (Di2, Mechanical)	HG 9-speed	CS-S500	FC-EM900 FC-M8150 FC-EM600	Single	SM-CRE61 38T/44T	46.5	Single, w/o	-	50
					CR-ET600 38T/44T	50	Double, Single, w/o	-	
NEXUS INTER-8 (Di2, Mechanical)	HG Single speed 1/2 inch x 1/8 inch	SM-GEAR		Single	SM-CRE61 38T/44T	46.5	Single, w/o	-	85
					CR-ET600 38T/44T	50	Double, Single, w/o	-	
NEXUS INTER-5E (Di2, Mechanical)	HG	CS-C7000		Single	SM-CRE61 38T/44T	46.5	Single, w/o	-	85
					CR-ET600 38T/44T	50	Double, Single, w/o	-	

12-speed Rear derailleur spec.

Shifting system	Chain type	Rear sprocket	Crank arm	Front shifting system	Chainring	Chain line (mm)	Chain guard	Chain device	Maximum torque from drive unit (Nm)
HYPERGLIDE+ 12-speed (Di2, Mechanical)	HG 12-speed	HYPERGLIDE+ 12-speed	FC-M8050 FC-E8050 FC-E8000	Single	CR-EM800 32T	55	-	CD-EM800 w/o plate	* DU-E8000/ DU-E8080: 70 DU-E7000: 60
					SM-CRE80-12-SB 34T/36T	56.5	-	CD-EM800	DU-E8000/ DU-E8080: 70 DU-E7000: 60
					SM-CRE80-12-B 34T/36T/38T	55	-	CD-EM800 (Chain line: 55mm)	
					SM-CRE70-12-B 36T	55	-	CD-EM800 (Chain line: 55mm)	
					SM-CRE80-12-B 34T/36T/38T	53	-	CD-EM800 SM-CDE80 SM-CDE70	
					SM-CRE70-12-B 36T	53	-	CD-EM800 SM-CDE80 SM-CDE70	
					SM-CRE80-R 47T	50	-	-	
					SM-CRE70-12 42T	50	Double	-	

* Perfect shifting performance by high torque is not required.

11/10-speed Rear derailleur spec.

Shifting system	Chain type	Rear sprocket	Crank arm	Front shifting system	Chainring	Chain line (mm)	Chain guard	Chain device	Maximum torque from drive unit (Nm)
LINKGLIDE (Di2, Mechanical)	LINKGLIDE HG 11-speed	LINKGLIDE		Single	SM-CRE80-B 34T/38T	55	-	CD-EM800 (Chain line: 55 mm)	DU-E8000/ DU-E8080: 70 DU-E7000: 60
					SM-CRE70-B 34T	55	-	CD-EM800 (Chain line: 55 mm)	
					SM-CRE80-B 34T/38T	53	-	CD-EM800 SM-CDE80 SM-CDE70	
					SM-CRE80-R 47T	50	-	-	
HG 11-speed (Di2, Mechanical)	LINKGLIDE HG 11-speed	HG 11-speed	FC-M8050 FC-E8050 FC-E8000	Single	SM-CRE80 34T/38T	50	-	SM-CDE80 w/o plate	DU-E8000/ DU-E8080: 70 DU-E7000: 60
					SM-CRE80 44T	50	Double	-	
					SM-CRE70-B 34T	53	-	CD-EM800 SM-CDE80 SM-CDE70	
					SM-CRE70 38T	50	-	SM-CDE80 w/o plate	
HG 10-speed (Mechanical)	HG-X 10-speed HG 10-speed	HG 10-speed		Single	SM-CRE70 38T	50	Double	-	DU-E8000/ DU-E8080: 70 DU-E7000: 60
					CR-ET600 38T/44T	50	Double	-	

12-speed Rear derailleur spec.

Shifting system	Chain type	Rear sprocket	Crank arm	Front shifting system	Chainring	Chain line (mm)	Chain guard	Chain device	Maximum torque from drive unit (Nm)
HYPERGLIDE+ 12-speed (Di2, Mechanical)	HG 12-speed	HYPERGLIDE+ 12-speed	FC-M8050 FC-E8050 FC-E8000 FC-E6100	Single	SM-CRE80-12-SB 34T/36T	56.5	-	-	60
					SM-CRE80-12-B 34T/36T/38T	55	-	-	
					SM-CRE70-12-B 36T	55	-	-	
					SM-CRE80-12-B 34T/36T/38T	53	-	-	
					SM-CRE70-12-B 36T	53	-	-	
					SM-CRE80-R 47T	50	Double	-	
					SM-CRE70-12 42T	50	Double	-	

11/10-speed Rear derailleur spec.

Shifting system	Chain type	Rear sprocket	Crank arm	Front shifting system	Chainring	Chain line (mm)	Chain guard	Chain device	Maximum torque from drive unit (Nm)				
LINKGLIDE (Di2, Mechanical)	LINKGLIDE HG 11-speed	LINKGLIDE	FC-M8050 FC-E8050 FC-E8000 FC-E6100	Single	SM-CRE80-B 34T/38T	55	-	-	60				
					SM-CRE70-B 34T	55	-	-					
					SM-CRE80-B 34T/38T	53	-	-					
					SM-CRE80-R 47T	50	-	-					
HG 11-speed (Di2, Mechanical)	LINKGLIDE HG 11-speed	HG 11-speed			FC-M8050 FC-E8050 FC-E8000 FC-E6100	Single	SM-CRE80 34T/38T	50	-	-	60		
							SM-CRE80 44T	50	Double	-			
							SM-CRE70-B 34T	53	-	-			
HG 10-speed (Mechanical)	HG-X 10-speed HG 10-speed	HG 10-speed					FC-M8050 FC-E8050 FC-E8000 FC-E6100	Single	SM-CRE70 38T	50	-	-	60
									SM-CRE70 38T	50	Double	-	
									CR-ET600 38T/44T	50	Double	-	
			FC-M8050 FC-E8050 FC-E8000 FC-E6100	Single					SM-CRE61 38T/44T	46.5	Double, Single, w/o	-	60

Internal geared hub spec.

Shifting system	Chain type	Rear sprocket	Crank arm	Front shifting system	Chainring	Chain line (mm)	Chain guard	Chain device	Maximum torque from drive unit (Nm)		
ALFINE INTER-11/8 (Di2, Mechanical)	HG 9-speed	CS-S500	FC-M8050 FC-E8050 FC-E8000 FC-E6100	Single	SM-CRE61 38T/44T	46.5	Double, Single, w/o	-	50		
					CR-ET600 38T/44T	50	Double, Single, w/o	-			
NEXUS INTER-8 (Di2, Mechanical)	HG Single speed 1/2 inch x 1/8 inch	SM-GEAR		FC-M8050 FC-E8050 FC-E8000 FC-E6100	Single	SM-CRE61 38T/44T	46.5	Double, Single, w/o	-	60	
						CR-ET600 38T/44T	50	Double, Single, w/o	-		
NEXUS INTER-5E (Di2, Mechanical)	HG	CS-C7000			FC-M8050 FC-E8050 FC-E8000 FC-E6100	Single	SM-CRE61 38T/44T	46.5	Single, w/o	-	60
							CR-ET600 38T/44T	50	Double, Single, w/o	-	

E6000 series C-658

11/10/9-speed Rear derailleur spec.

Shifting system	Chain type	Rear sprocket	Crank arm	Front shifting system	Chainring	Chain line (mm)	Chain guard	Chain tensioner	Maximum torque from drive unit (Nm)
HG 11-speed (Mechanical)	LINKGLIDE HG 11-speed	HG 11-speed	FC-E6000 FC-E6010 FC-E5000 FC-E5010	Single	SM-CRE60 38T/44T	46.5	Double	-	50
HG 10-speed (Mechanical)	HG-X 10-speed HG 10-speed	HG 10-speed		Single	SM-CRE60 38T/44T	46.5	Double	-	50
HG 9-speed (Mechanical)	HG 9-speed	HG 9-speed		Single	SM-CRE60 38T/44T	46.5	Double	-	50

Internal geared hub spec.

Shifting system	Chain type	Rear sprocket	Crank arm	Front shifting system	Chainring	Chain line (mm)	Chain guard	Chain tensioner	Maximum torque from drive unit (Nm)
ALFINE INTER-11/8 (Di2, Mechanical)	HG 9-speed HG 8-speed	SM-GEAR	FC-E6000 FC-E6010 FC-E5000 FC-E5010	Single	SM-CRE60 38T/44T	46.5	w/o	CT-S510	50
		CS-S500				46.5	Double	CT-S500	
NEXUS INTER-8 (Di2, Mechanical)	HG Single speed 1/2 inch x 1/8 inch	SM-GEAR		Single	SM-CRE60 38T/44T	46.5	Single, w/o	CT-S510 *	
NEXUS INTER-5E (Di2, Mechanical)	HG	CS-S500		Single	SM-CRE60 38T/44T	46.5	Double	CT-S500	

* Not compatible with CN-NX10

E5000 / E5080 series C-659

11/10-speed Rear derailleur spec.

Shifting system	Chain type	Rear sprocket	Crank arm	Front shifting system	Chainring	Chain line (mm)	Chain guard	Chain device	Maximum torque from drive unit (Nm)
LINKGLIDE (Di2, Mechanical)	LINKGLIDE HG 11-speed	LINKGLIDE	FC-E6000 FC-E6010 FC-E5000 FC-E5010	Single	SM-CRE50 38T/44T	46.5	Double, Single, w/o	-	40
HG 11-speed (Di2, Mechanical)	LINKGLIDE HG 11-speed	HG 11-speed			SM-CRE50 38T/44T	46.5	Double, Single, w/o	-	40
HG 10-speed (Mechanical)	HG-X 10-speed HG 10-speed	HG 10-speed			SM-CRE50 38T/44T	46.5	Double, Single, w/o	-	40

Internal geared hub spec.

Shifting system	Chain type	Rear sprocket	Crank arm	Front shifting system	Chainring	Chain line (mm)	Chain guard	Chain device	Maximum torque from drive unit (Nm)
ALFINE INTER-11/8 (Di2, Mechanical)	HG 9-speed	CS-S500	FC-E6000 FC-E6010 FC-E5000 FC-E5010	Single	SM-CRE50 38T/44T	46.5	Double, Single, w/o	-	40
NEXUS INTER-8 (Di2, Mechanical)	HG Single speed 1/2 inch x 1/8 inch	SM-GEAR		Single	SM-CRE50 38T/44T	46.5	Double, Single, w/o	-	
NEXUS INTER-5E (Di2, Mechanical)	HG	CS-C7000		Single	SM-CRE50 38T/44T	46.5	Double, Single, w/o	-	

Switch unit / cycle computer and brake lever compatibility

C-421

For Hydraulic Disc brake

I-SPEC EV type brake lever

Model No.	Di2 shift switch			SHIMANO STEPS cycle computer		
	SW-M9050	SW-M8050	SW-M8150-IR	SC-E5000 *1	SC-E5003 *1	SC-EN500 *1
BL-M9100	-	-	✓	✓	-	✓
BL-M9120	-	-	✓	✓	-	✓
BL-M8100	-	-	✓	✓	-	✓
BL-M7100	-	-	✓	✓	-	✓
BL-M6100	-	-	✓	✓	-	✓
BL-M4100	-	-	✓	✓	-	✓

Model No.	SHIMANO STEPS switch unit						
	SW-EM800-L	SW-E8000-L	SW-E7000	SW-E6010	SW-E6000	SW-EN600-L	SW-EN600-R
BL-M9100	✓	-	✓	✓	✓	✓	✓
BL-M9120	✓	-	✓	✓	✓	✓	✓
BL-M8100	✓	-	✓	✓	✓	✓	✓
BL-M7100	✓	-	✓	✓	✓	✓	✓
BL-M6100	✓	-	✓	✓	✓	✓	✓
BL-M4100	✓	-	✓	✓	✓	✓	✓

*1: I-SPEC EV compatible spec only

I-SPEC II type brake lever

Model No.	Di2 shift switch			SHIMANO STEPS cycle computer		
	SW-M9050	SW-M8050	SW-M8150-R	SC-E5000	SC-E5003	SC-EN500
BL-M9000	✓	✓	✓	✓	✓	✓
BL-M9020	✓	✓	✓	✓	✓	✓
BL-M8000	✓	✓	✓	✓	✓	✓
BL-T8100	✓	✓	✓	✓	✓	✓
BL-T8000	✓	✓	✓	✓	✓	✓
BL-M7000	✓	✓	✓	✓	✓	✓
BL-M6000	✓	✓	✓	✓	✓	✓
BL-T6000	✓	✓	✓	✓	✓	✓
BL-RS600	✓	✓	✓	✓	✓	✓
BL-MT501	✓	✓	✓	✓	✓	✓

Model No.	SHIMANO STEPS switch unit						
	SW-EM800-L	SW-E8000-L	SW-E7000	SW-E6010	SW-E6000	SW-EN600-L	SW-EN600-R
BL-M9000	✓	✓	✓	✓	✓	✓	✓
BL-M9020	✓	✓	✓	✓	✓	✓	✓
BL-M8000	✓	✓	✓	✓	✓	✓	✓
BL-T8100	✓	✓	✓	✓	✓	✓	✓
BL-T8000	✓	✓	✓	✓	✓	✓	✓
BL-M7000	✓	✓	✓	✓	✓	✓	✓
BL-M6000	✓	✓	✓	✓	✓	✓	✓
BL-T6000	✓	✓	✓	✓	✓	✓	✓
BL-RS600	✓	✓	✓	✓	✓	✓	✓
BL-MT501	✓	✓	✓	✓	✓	✓	✓

Other clamp band type brake lever

Model No.	Di2 shift switch			SHIMANO STEPS cycle computer		
	SW-M9050	SW-M8050	SW-M8150-R	SC-E5000	SC-E5003	SC-EN500
BL-MT402-3A	✓	✓	✓	✓	✓	✓
BL-MT401	✓	✓	✓	✓	✓	✓
BL-MT201	✓	✓	✓	✓	✓	✓
BL-MT200	✓	✓	✓	✓	✓	✓

Model No.	SHIMANO STEPS switch unit						
	SW-EM800-L	SW-E8000-L	SW-E7000	SW-E6010	SW-E6000	SW-EN600-L	SW-EN600-R
BL-MT402-3A	✓	✓	✓	✓	✓	✓	✓
BL-MT401	✓	✓	✓	✓	✓	✓	✓
BL-MT201	✓	✓	✓	✓	✓	✓	✓
BL-MT200	✓	✓	✓	✓	✓	✓	✓

Brake lever for mechanical brake (Mechanical disc brake / V-BRAKE / Caliper brake / Cantilever brake)

Refer to SPEC HANDBOOK for compatible brake type.

Model No.	SHIMANO STEPS cycle computer		
	SC-E5000	SC-E5003	SC-EN500
BL-T610	✓	✓	✓
BL-T611	✓	✓	✓
BL-T4000	✓	✓	✓
BL-T4010	✓	✓	✓
BL-C6010	✓	✓	✓
BL-4700	✓	✓	✓
BL-R3000	✓	✓	✓
BL-R2000	✓	✓	✓
BL-R780	✓	✓	✓
BL-R550	✓	✓	✓

Model No.	SHIMANO STEPS switch unit						
	SW-EM800-L	SW-E8000-L	SW-E7000	SW-E6010	SW-E6000	SW-EN600-L	SW-EN600-R
BL-T610	✓	✓	✓	✓	✓	✓	✓
BL-T611	✓	✓	✓	✓	✓	✓	✓
BL-T4000	✓	✓	✓	✓	✓	✓	✓
BL-T4010	✓	✓	✓	✓	✓	✓	✓
BL-C6010	✓	✓	✓	✓	✓	✓	✓
BL-4700	✓	✓	✓	✓	✓	✓	✓
BL-R3000	✓	✓	✓	✓	✓	✓	✓
BL-R2000	✓	✓	✓	✓	✓	✓	✓
BL-R780	✓	✓	✓	✓	✓	✓	✓
BL-R550	✓	✓	✓	✓	✓	✓	✓

Battery

Batteries shipped in the country / region are different.

For Gen.2 battery management system

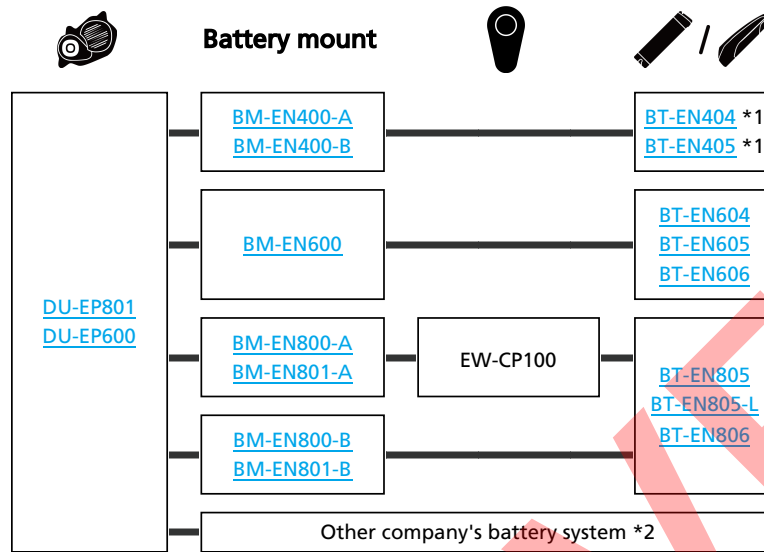

Limitation of function

- *1 These batteries don't support over 500W drive unit power output
- *2 Some of these batteries don't support over 500W drive unit power output

For 1st generation battery management system

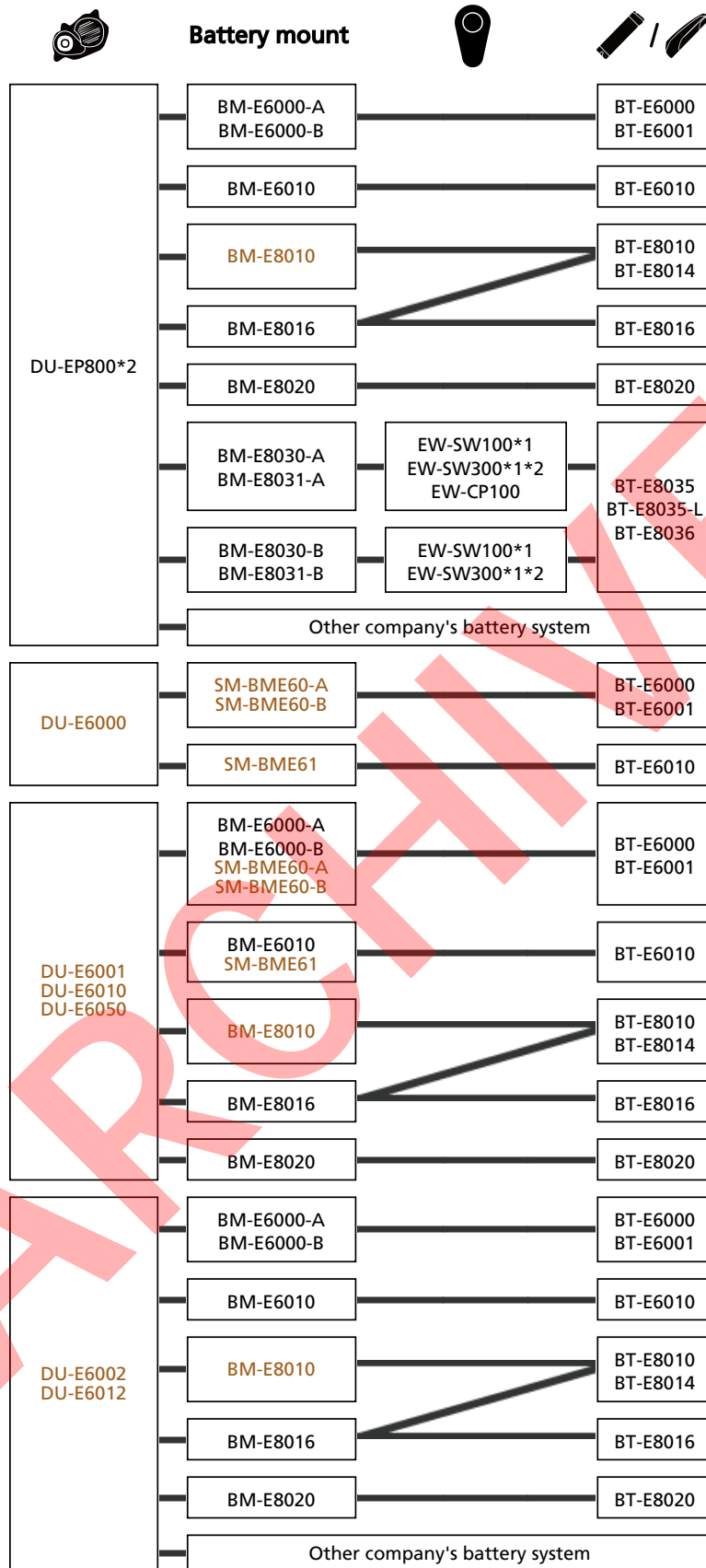

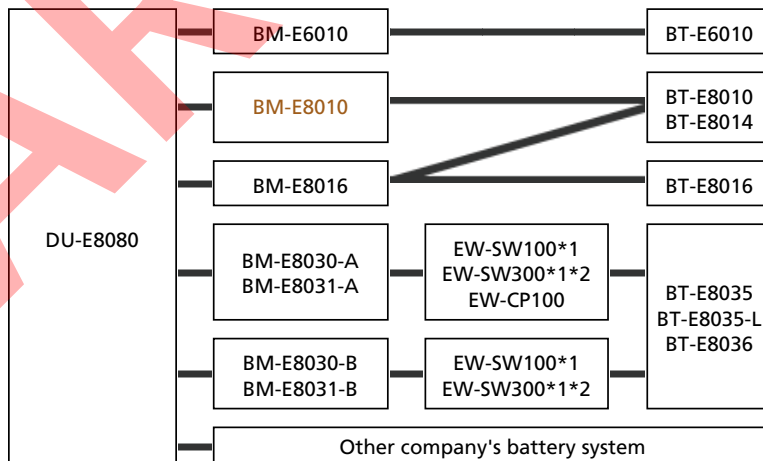
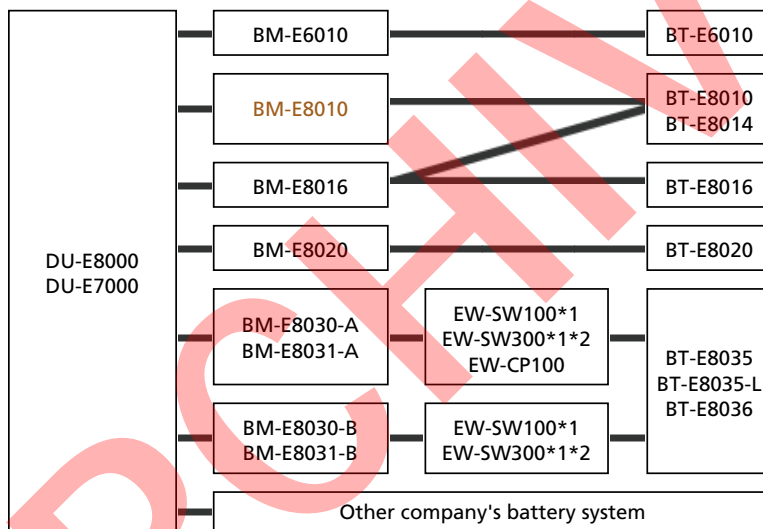
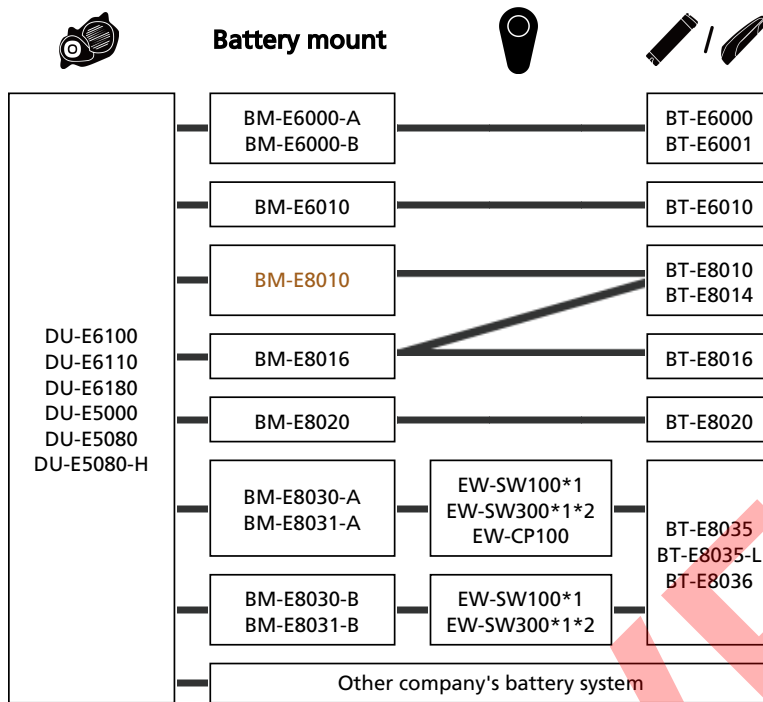

Limitation of function

*1: Can't use with SC-E6010

*2: This unit has SD300 port, and needs EW-AD305 for connection to SD50 port unit.

External frame mount type

MTB, URBAN, Trekking use

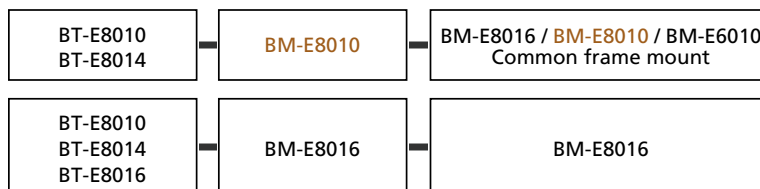

Built-in frame mount type

MTB, URBAN, Trekking use



ROAD, MTB, URBAN, Trekking use

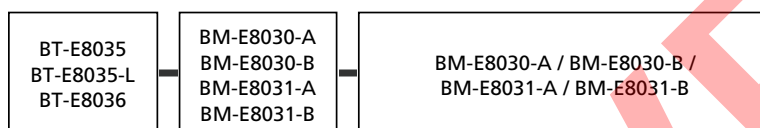

ARCHIVE

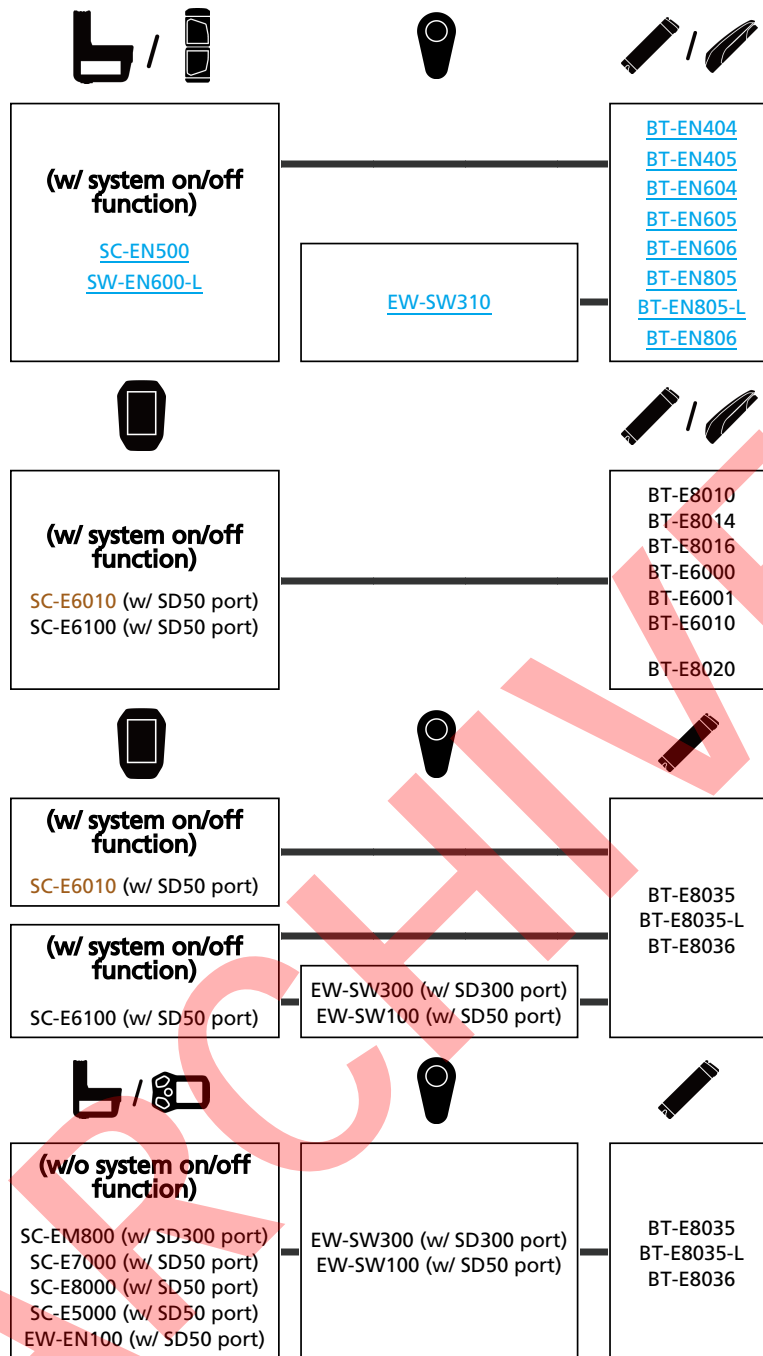

Speed sensor

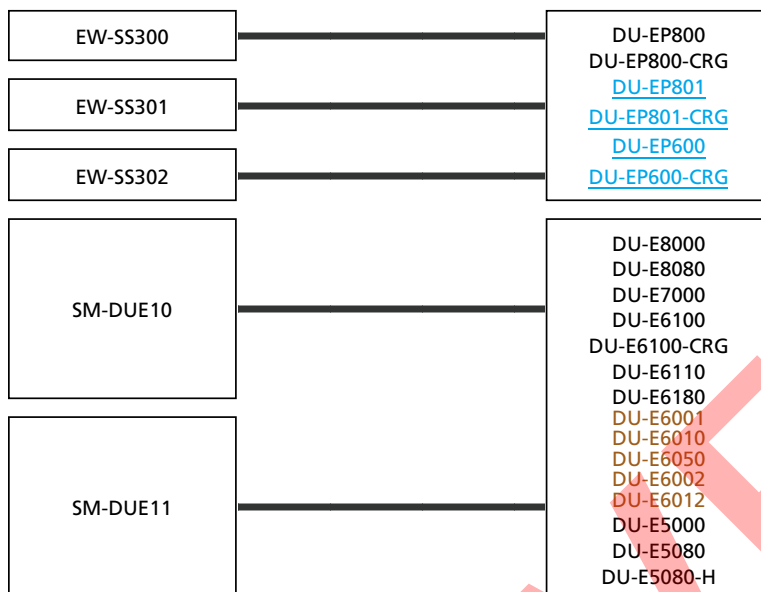

ARCHIVE

Battery and battery charger compatibility

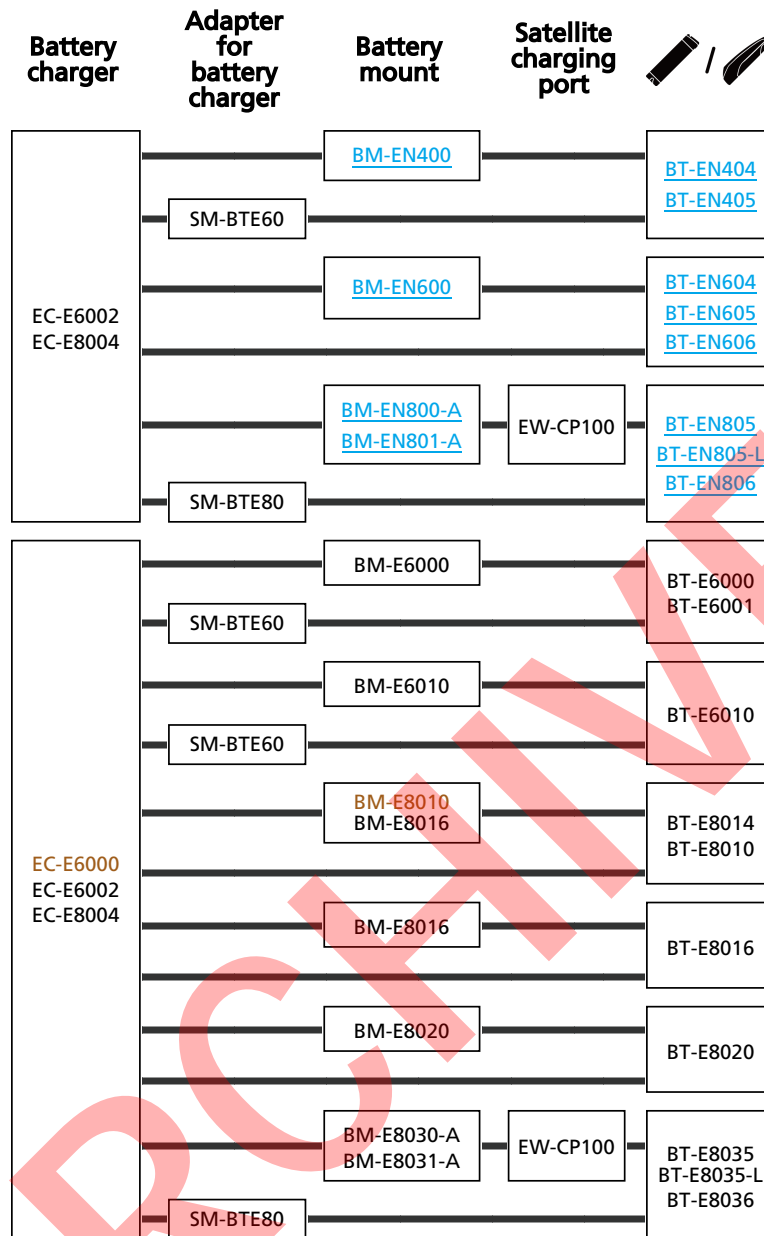

ABS main unit and drive unit compatibility

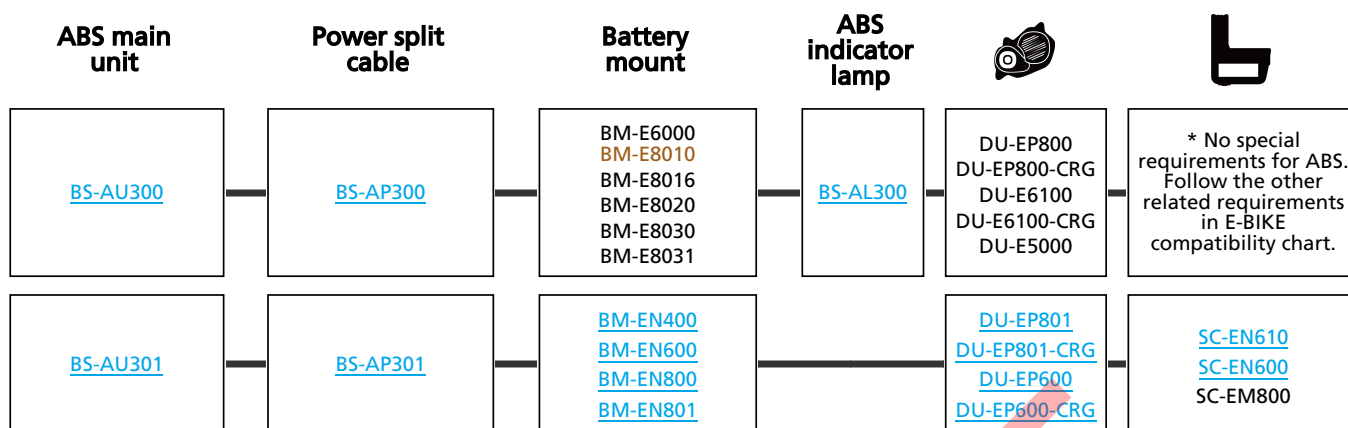

Wheel speed sensor and disc brake rotor compatibility

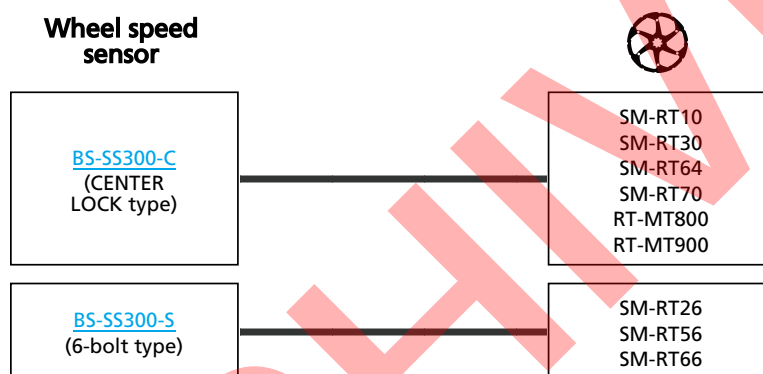

E-TUBE compatibility chart

C-473

Compatibility chart of E-TUBE PROJECT Cyclist/Professional v5.1.2

Di2 with BT-DN300

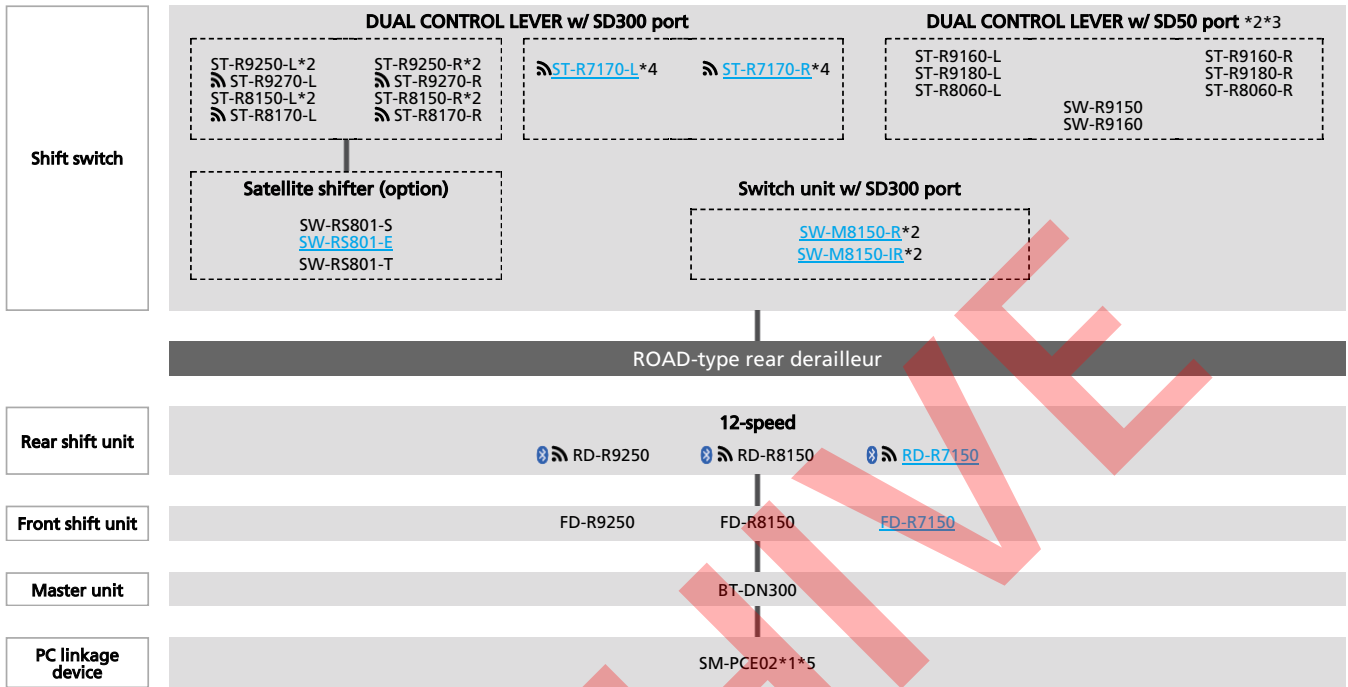

Limitation of function with BT-DN300

- *1 To connect SM-PCE02, EW-AD305 is needed
- *2 Wired connection to BT-DN300 only
- *3 EW-AD305 is needed
- *4 Wireless connection only
- *5 Not supported by E-TUBE PROJECT Cyclist

Di2 with BM-DN100 / BT-DN110

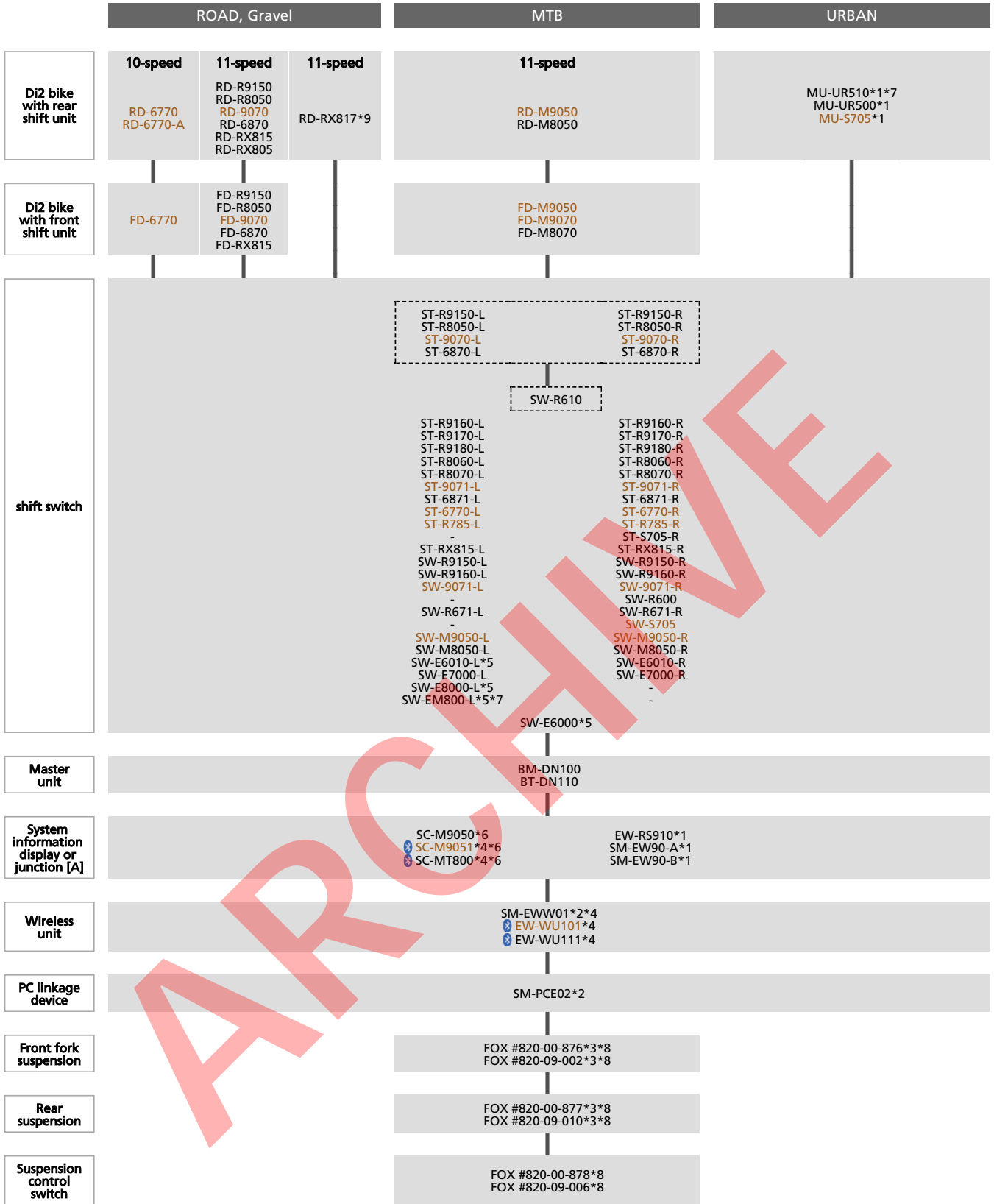

Limitation of function with BM-DN100 / BT-DN110

- *1 Shifting adjustment mode for MU-S705, MU-UR500 and MU-UR510 is not supported (need E-TUBE PROJECT to adjust)
- *2 Not supported by E-TUBE PROJECT Cyclist
- *3 A designated control switch and/or the combination SW-M9050/SW-M8050-L with SC-M9050/SC-M9051/SC-MT800 is required to operate
- *4 The system accepts just 1 unit with wireless chip (doesn't work if plural units with wireless chip are connected)
- *5 Need to change switch setting by E-TUBE PROJECT
- *6 SC-M9050, SC-M9051 or SC-MT800 is required for SYNCHRONIZED SHIFT in MTB category
- *7 This unit has SD300 port, and needs EW-AD305 for connection
- *8 Only supported by E-TUBE PROJECT Cyclist
- *9 For front single models only. Cannot be used in combination with a front derailleur.

ARCHIVE

Di2 with SM-BMR1 / SM-BMR2 / SM-BTR2

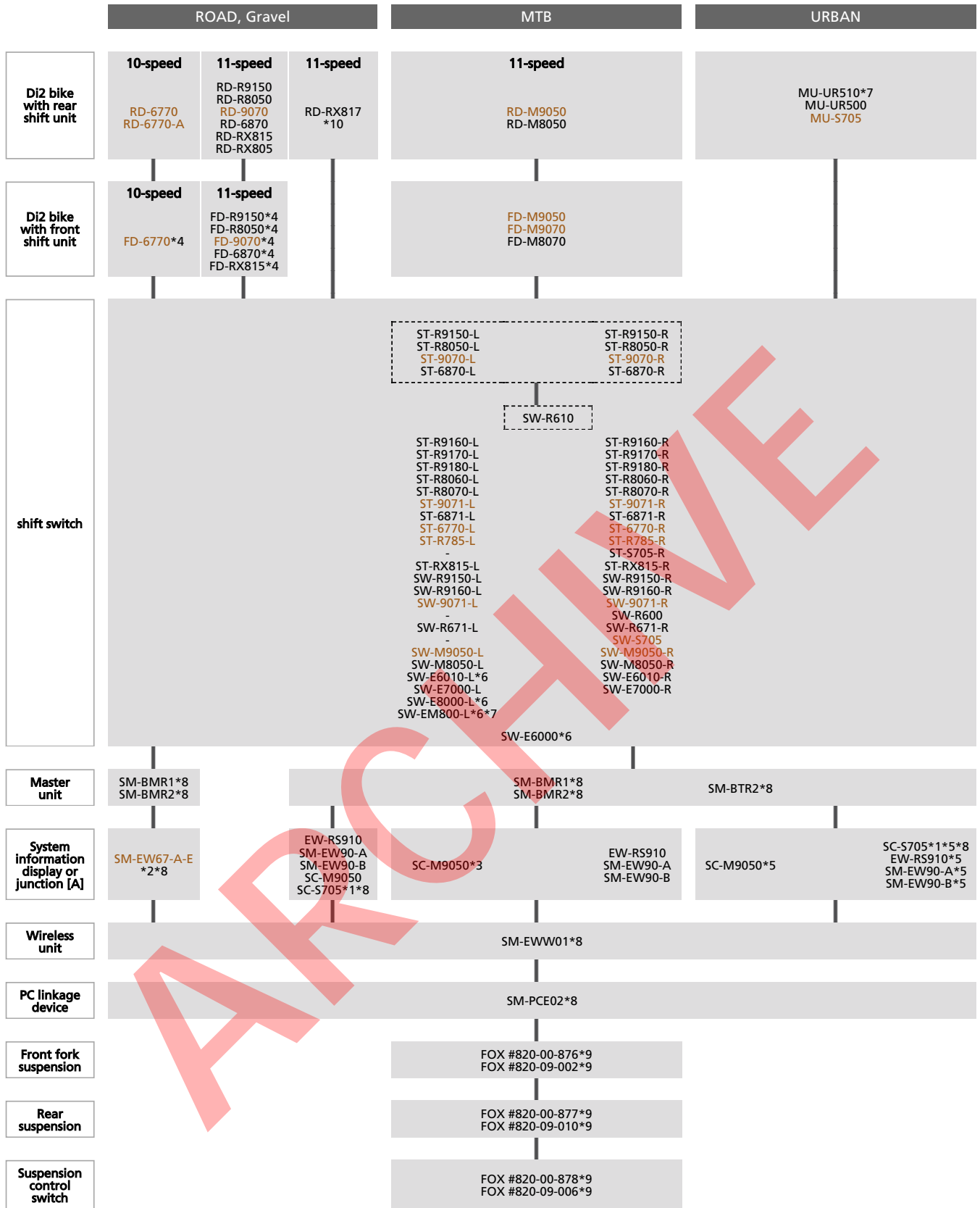

Limitation of function with SM-BMR1 / SM-BMR2 / SM-BTR2

*1 SC-S705

- Front derailleur position will not appear on display.
- Recovery from Rear derailleur protection function is not available.
- Front / Rear derailleur adjustment mode is not available. Use E-TUBE PROJECT software.
- SC-S705 has only 1 SD50 port for ST / SW.
- SC-S705 may not turn on the display by front shift switch.

*2 SM-BCR2 requires any device which has charging port.

SM-EW67-A-E (Junction [A]) is not compatible with SM-BCR2 and SM-BTR2.

*3 SC-M9050 is required for SYNCHRONIZED SHIFT in case with MTB-type Rear Derailleur

*4 SYNCHRONIZED SHIFT is not available with Road-type Rear Derailleur

*5 Shifting adjustment mode for MU-S705 , MU-UR500 and MU-UR510 is not supported (need E-TUBE PROJECT to adjust)

*6 Need to change switch setting by E-TUBE PROJECT

*7 This unit has SD300 port, and needs EW-AD305 for connection

*8 Only supported by E-TUBE PROJECT Cyclist

*9 Not supported by E-TUBE PROJECT Cyclist

*10 For front single models only. Cannot be used in combination with a front derailleur.

ARCHIVE

Compatibility chart of E-TUBE PROJECT Professional v5.1.2

EW-EX010 for BOSCH eBike

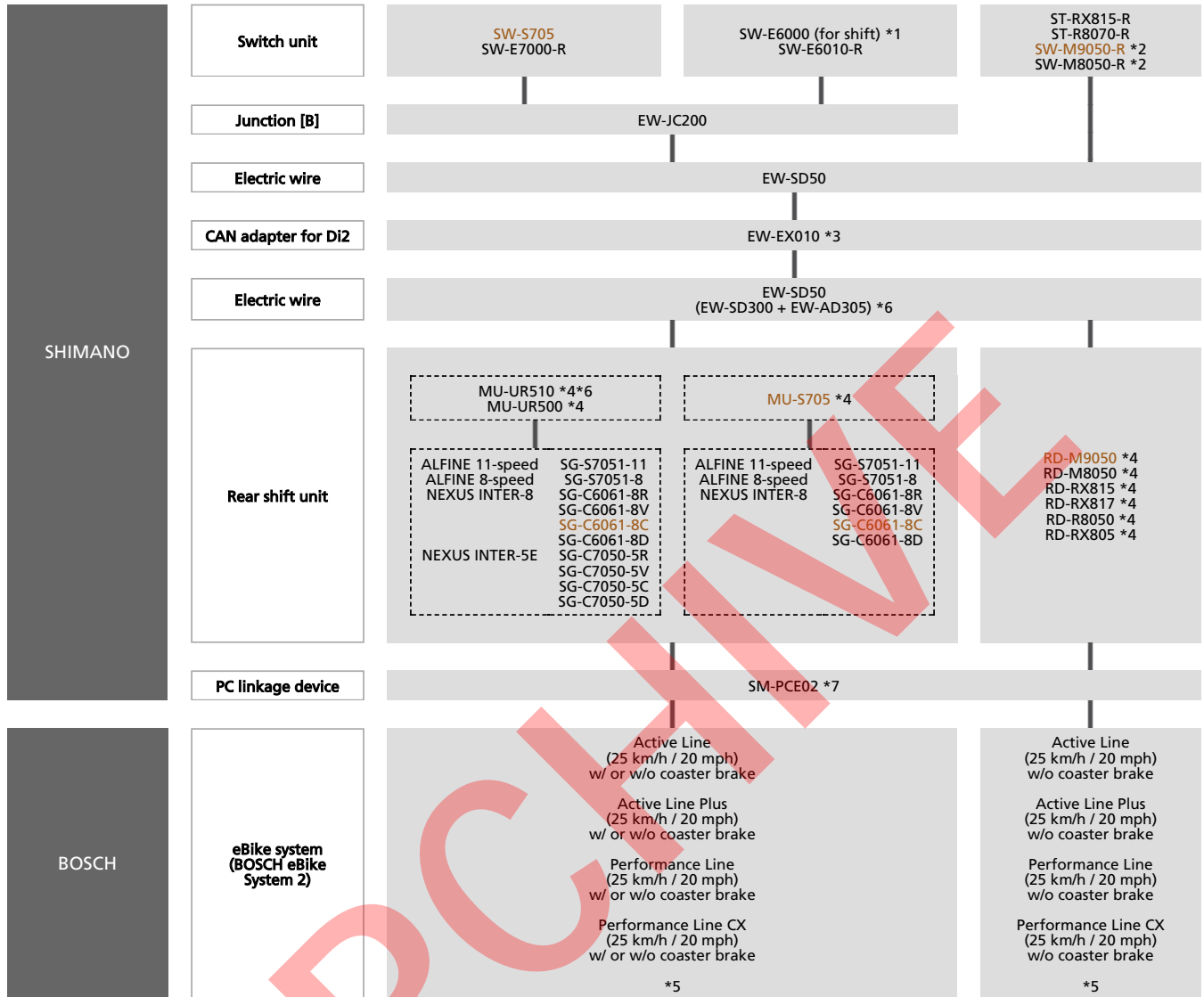

Limitation of function

- *1: Need to change switch setting by E-TUBE PROJECT
- *2: Not support full automatic shift
- *3: EW-EX010 and BOSCH eBike system are connected by Y-harness which is provided by BOSCH
- *4: Full automatic shift is available only with internal geared hub by MU-UR510 / MU-UR500 / MU-S705 (Not available with rear derailleur)
- *5: No compatibility with "Classic+ Line" and "Performance Line (45 km/h)"
- *6: MU-UR510 has SD300 port, and needs EW-AD305 for connection with SD50 port unit.
- *7: Not supported by E-TUBE PROJECT Cyclist

Compatibility between Bracket and ID/SC

C-548

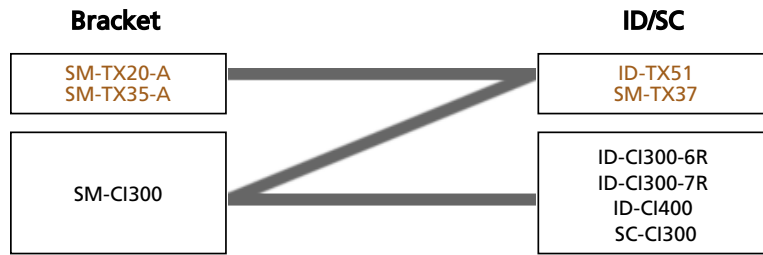

ARCHIVE